

## Chapter 8 Antenna Theory

### 8-1 Calculation of EM Fields of Antennas

**L. J. Chu (朱蘭成):** 朱蘭成院士生於民國 2 年，民國 62 年逝世。民國 47 年 4 月當選第二屆中研院院士，是電磁波及雷達研究方面的三大國際權威之一。



**Y. T. Lo (羅遠梓):** Yuen Tze Lo (MSEE'49, PhD'52) died in 2002. He was 82. Lo invented the broadband television receiving antenna, and he developed the cavity model theory for microstrip patch antennas now used in global positioning systems (GPS). In 1986, Lo was elected to the National Academy of Engineering for inventions and innovative ideas that significantly advanced the theory and design of antennas and arrays.

**J. A. Kong(孔金甌):** 孔教授 1942 年出生於中國江蘇，2007 年去世，享年 65 歲。孔教授是孔子第七十四代孫，為臺大電機學士，交大碩士，美國 Syracuse 大學博士，他自 1969 年任教麻省理工學院電機系，為電磁波泰斗，曾出版 30 本電磁學著作和 700 篇研究論文。

*Case 1 Given*  $\vec{J}(x, y, z, t), \vec{A} = \frac{\mu}{4\pi} \iiint_{V'} \frac{\vec{J} e^{-jkR}}{R} dv', \vec{H} = \frac{1}{\mu} \nabla \times \vec{A}, \vec{E} = \frac{1}{j\omega\epsilon} \nabla \times \vec{H}$

*Case 2 Given*  $\rho(x, y, z, t), V = \frac{1}{4\pi\epsilon} \iiint_{V'} \frac{\rho e^{-jkR}}{R} dv', \nabla \cdot \vec{J} = -\frac{\partial \rho}{\partial t}, \vec{E} = -\nabla V - \frac{\partial \vec{A}}{\partial t} = \frac{1}{j\omega\epsilon} \nabla \times \vec{H}$

**Eg. (a)** Assume the spatial distribution of the current on a very thin center-fed half-wave dipole lying along the z-axis to be  $I_0 \cos(\beta z)$ , where  $\beta = 2\pi/\lambda$ . Find the charge distribution on the dipole.

(Sol.)  $\nabla \cdot \vec{J} = -j\omega\rho \Rightarrow \rho = \frac{j}{\omega} \frac{dI(z)}{dz} = -j \frac{\beta}{\omega} I_0 \sin \beta z$

**Stratton-Chu formulas for calculating EM Fields of antennas: (by L. J. Chu)**

$$\vec{E}(\vec{r}) = \iiint_{V'} [-j\omega\mu\vec{G}\vec{J} + \frac{\rho}{\epsilon}\nabla'G - \vec{J}_m \times \nabla'G]dV' + \iint_{S'} [-j\omega\mu G(\hat{a}_n \times \vec{H}) + (\hat{a}_n \cdot \vec{E})\nabla'G + (\hat{a}_n \times \vec{E}) \times \nabla'G]dS'$$

$$\vec{H}(\vec{r}) = \iiint_{V'} [-j\omega\epsilon\vec{G}\vec{J}_m + \frac{\rho_m}{\mu}\nabla'G + \vec{J} \times \nabla'G]dV' + \iint_{S'} [j\omega\epsilon G(\hat{a}_n \times \vec{E}) + (\hat{a}_n \cdot \vec{H})\nabla'G + (\hat{a}_n \times \vec{H}) \times \nabla'G]dS'$$

where  $G = \frac{e^{-jkr}}{4\pi r}$  is Green's function in the free space.

## Elemental electrical dipole (Hertzian dipole):

$$\vec{p} = \hat{z}Qd\ell$$

$$I = \pm \frac{dQ}{dt} = \pm j\omega Q, \quad Q = \pm \frac{I}{j\omega}$$

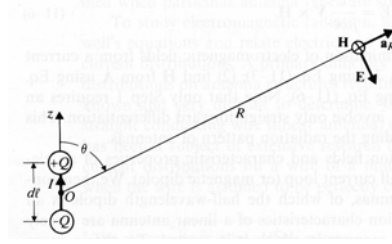

$$\Rightarrow \vec{A} = \hat{z} \frac{\mu_0 Id\ell}{4\pi} \cdot \frac{e^{-j\beta R}}{R} = (\hat{a}_R \cos\theta - \hat{a}_\theta \sin\theta) \frac{\mu_0 Id\ell}{4\pi} \cdot \frac{e^{-j\beta R}}{R} = \hat{a}_R A_R + \hat{a}_\theta A_\theta + \hat{a}_\phi A_\phi$$

$$\Rightarrow \begin{cases} A_R = A_z \cos\theta = \frac{\mu_0 Id\ell}{4\pi} \left(\frac{e^{-j\beta R}}{R}\right) \cos\theta \\ A_\theta = -A_z \sin\theta = -\frac{\mu_0 Id\ell}{4\pi} \left(\frac{e^{-j\beta R}}{R}\right) \sin\theta \\ A_\phi = 0 \end{cases} \Rightarrow \begin{cases} \vec{H} = \frac{1}{\mu_0} \nabla \times \vec{A} = \hat{a}_\phi \frac{1}{\mu_0 R} \left[ \frac{\partial}{\partial R} (R A_\theta) - \frac{\partial A_R}{\partial \theta} \right] \\ = -\hat{a}_\phi \frac{Id\ell}{4\pi} \beta^2 \sin\theta \cdot \left[ \frac{1}{j\beta R} + \frac{1}{(j\beta R)^2} \right] e^{-j\beta R} \end{cases}$$

$$\vec{E} = \frac{1}{j\omega\epsilon_0} \nabla \times \vec{H} = \frac{1}{j\omega\epsilon_0} \left[ \hat{a}_R \frac{1}{R \sin\theta} \frac{\partial}{\partial \theta} (H_\phi \sin\theta) - \hat{a}_\theta \frac{1}{R} \frac{\partial}{\partial R} (R H_\phi) \right]$$

$$\Rightarrow \begin{cases} E_R = -\frac{Id\ell}{4\pi} \eta_0 \beta^2 2 \cos\theta \left[ \frac{1}{(j\beta R)^2} + \frac{1}{(j\beta R)^3} \right] e^{-j\beta R} \\ E_\theta = -\frac{Id\ell}{4\pi} \eta_0 \beta^2 \sin\theta \left[ \frac{1}{j\beta R} + \frac{1}{(j\beta R)^2} + \frac{1}{(j\beta R)^3} \right] e^{-j\beta R} \\ E_\phi = 0, \text{ where } \eta_0 = \sqrt{\mu_0 / \epsilon_0} \cong 120\pi(\Omega) \end{cases}$$

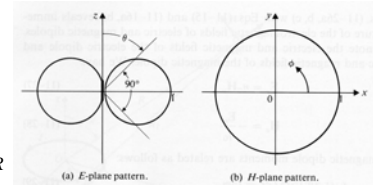

## Far field of a Hertzian dipole: if $\beta R = 2\pi R/\lambda \gg 1$

$$H_\phi = j \frac{Id\ell}{4\pi} \left(\frac{e^{-j\beta R}}{R}\right) \beta \sin\theta, \quad E_\theta = j \frac{Id\ell}{4\pi} \left(\frac{e^{-j\beta R}}{R}\right) \eta_0 \beta \sin\theta$$

## Elemental magnetic dipoles: $\vec{m} = \hat{z}IS = \hat{z}m$

$$\vec{m} = \hat{z}I\pi b^2 = \hat{z}m \Rightarrow \vec{A} = \frac{\mu_0 I}{4\pi} \oint \frac{e^{-j\beta R_1}}{R_1} d\vec{\ell}'$$

$$e^{-j\beta R_1} = e^{-j\beta R} e^{-j\beta(R_1 - R)} \cong e^{-j\beta R} [1 - j\beta(R_1 - R)]$$

$$\vec{A} = \frac{\mu_0 I}{4\pi} e^{-j\beta R} \left[ (1 + j\beta R) \oint \frac{d\vec{\ell}'}{R_1} - j\beta \oint d\vec{\ell}' \right] \Rightarrow \vec{A} = \hat{a}_\phi \frac{\mu_0 m}{4\pi R^2} (1 + j\beta R) e^{-j\beta R} \sin\theta$$

$$\vec{H} = \frac{1}{\mu_0} \nabla \times \vec{A} \quad \text{and} \quad \vec{E} = \frac{1}{j\omega\epsilon_0} \nabla \times \vec{H}$$

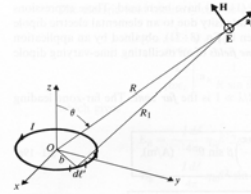

$$\Rightarrow \begin{cases} E_\phi = \frac{j\omega\mu_0 m}{4\pi} \beta^2 \sin\theta \left[ \frac{1}{j\beta R} + \frac{1}{(j\beta R)^2} \right] e^{-j\beta R} \\ H_R = -\frac{j\omega\mu_0 m}{4\pi\eta_0} \beta^2 2 \cos\theta \left[ \frac{1}{(j\beta R)^2} + \frac{1}{(j\beta R)^3} \right] e^{-j\beta R} \\ H_\theta = -\frac{j\omega\mu_0 m}{4\pi\eta_0} \beta^2 \sin\theta \left[ \frac{1}{j\beta R} + \frac{1}{(j\beta R)^2} + \frac{1}{(j\beta R)^3} \right] e^{-j\beta R} \end{cases}$$

### Far field of an elemental magnetic dipoles:

$$E_\phi = \frac{\omega\mu_0 m}{4\pi} \left( \frac{e^{-j\beta R}}{R} \right) \beta \sin\theta, \quad H_\theta = -\frac{\omega\mu_0 m}{4\pi\eta_0} \left( \frac{e^{-j\beta R}}{R} \right) \beta \sin\theta$$

**Eg. A small filamentary rectangular loop of dimensions  $L_x$  and  $L_y$  lies in the  $xy$ -plane with its center at the origin and sides parallel to the  $x$ - and  $y$ -axes. The loop carries a current  $i(t)=I_0\cos(\omega t)$ . Assuming  $L_x$  and  $L_y$  to be much less than the wavelength, find the expressions for the following quantities at a point in the far zone: (a) vector magnetic potential, (b) electric field intensity, (c) magnetic field intensity.**

$$\text{(Sol.) (a) } \vec{m} = \hat{z} I_0 \cos\omega t L_x L_y, \quad \vec{A} = \hat{a}_\phi \frac{\mu_0 I_0 \cos\omega t L_x L_y}{4\pi R} (1 + j\beta R) e^{-j\beta R} \cdot \sin\theta$$

$$\text{(b) } E_\phi = \frac{\omega\mu_0 I_0 \cos\omega t L_x L_y}{4\pi} \left( \frac{e^{-j\beta R}}{R} \right) \beta \sin\theta$$

$$\text{(c) } H_\theta = -\frac{\omega\mu_0 I_0 \cos\omega t L_x L_y}{4\pi\eta_0} \left( \frac{e^{-j\beta R}}{R} \right) \beta \sin\theta$$

**Eg. A composite antenna consists of an elemental Hertzian electric dipole of length  $L$  along the  $z$ -axis and an elemental magnetic dipole of area  $S$  lying in the  $xy$ -plane. Equal time-harmonic currents of amplitude  $I_0$  and angular frequency  $\omega$  flow in the dipoles. (a) Verify that the far field of the composite antenna is elliptically polarized. (b) Determine the condition for circular polarization.**

$$\text{(Sol.) (a) } \vec{E} = \hat{a}_\theta \frac{jI_0 L}{4\pi} \eta_0 \beta \sin\theta \frac{e^{-j\beta R}}{R} + \hat{a}_\phi \frac{\omega\mu_0 I_0 S}{4\pi\eta_0} \beta \sin\theta \frac{e^{-j\beta R}}{R} = \hat{a}_\theta E_\theta + \hat{a}_\phi E_\phi$$

$$\text{(b) } E_\theta = E_\phi \Rightarrow \eta_0 L = \frac{\omega\mu_0 S}{\eta_0}$$

**Duality between elemental electric and magnetic dipoles:** ( $E_e, H_e$ ) due to electric dipole and ( $E_m, H_m$ ) due to magnetic dipole

$$E_e \leftrightarrow \eta_0 H_m, \quad H_e \leftrightarrow -\frac{E_m}{\eta_0}, \quad Idl \leftrightarrow j\beta m = j\beta IS, \quad dl \leftrightarrow \beta S$$

## 8-2 Radiation Patterns of Antennas

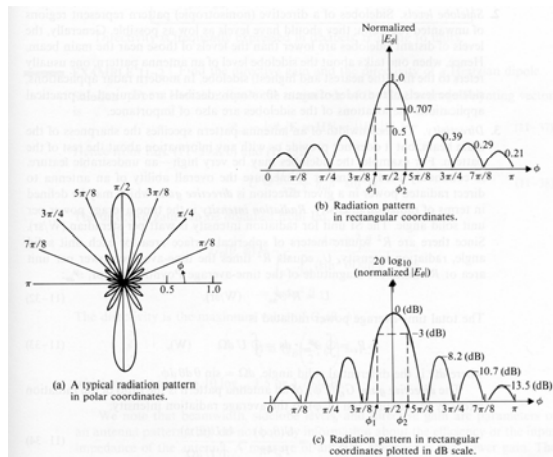

**Half-power beam width:** Angular width of main beam between the half-power (-3dB) points

**Sidelobe level:**  $(|E_{\max}| \text{ in one sidelobe}) / (|E_{\max}| \text{ in main beam})$

**Null positions:** Directions which have no radiations in the far-field zone.

**Directivity:**  $D = \frac{4\pi U_{\max}}{P_r} = \frac{4\pi |\vec{E}_{\max}|^2}{\int_0^{2\pi} \int_0^\pi |\vec{E}(\theta, \phi)|^2 \sin \theta d\theta d\phi}$ , where  $U = R^2 P_{av} \propto R^2 |\vec{E}|^2$

and  $P_r = \oint P_{av} dS = \oint U d\Omega \propto R^2 \int_0^{2\pi} \int_0^\pi |\vec{E}|^2 \sin \theta d\theta d\phi$  is the time-average radiated power

**Directivity gain:**  $G_D(\theta, \phi) = \frac{4\pi U(\theta, \phi)}{P_r} = \frac{4\pi |\vec{E}(\theta, \phi)|^2}{\int_0^{2\pi} \int_0^\pi |\vec{E}(\theta, \phi)|^2 \sin \theta d\theta d\phi}$ ,  $\therefore D = (G_D)_{\max}$

**Power gain:**  $G_p = \frac{4\pi U_{\max}}{P_i}$ , where  $P_i = P_r + P_l$ ,  $P_i$ : total input power,  $P_l$ : loss

**Radiation efficiency:**  $\eta_r = G_p / D = P_r / P_i$

**Eg. Find the directive gain and the directivity of a Hertzian dipole.**

(Sol.)  $P_{av} = \frac{1}{2} \text{Re} |E \times H^*| = \frac{1}{2} |E_\theta| |H_\phi|$ ,  $U = \frac{(Id\ell)^2}{32\pi^2} \eta_0 \beta^2 \sin^2 \theta$ .

$G_D(\theta, \phi) = \frac{4\pi \sin^2 \theta}{\int_0^{2\pi} \int_0^\pi (\sin^2 \theta) \sin \theta d\theta d\phi} = \frac{3}{2} \sin^2 \theta$ ,  $D = G_D(\frac{\pi}{2}, \phi) = 1.5 = 1.76 \text{ (dB)}$ .

**Eg. Find the radiation resistance of a Hertzian dipole.**

(Sol.)  $P_r = \frac{1}{2} \int_0^{2\pi} \int_0^\pi E_\theta H_\phi^* R^2 \sin \theta d\theta d\phi$

$$= \frac{I^2 (d\ell)^2}{32\pi^2} \eta_0 \beta^2 \int_0^{2\pi} \int_0^\pi \sin^3 \theta d\theta d\phi = \frac{I^2 (d\ell)^2}{12\pi} \eta_0 \beta^2 = \frac{I^2}{2} [80\pi^2 (\frac{d\ell}{\lambda})^2] = \frac{I^2}{2} R_r$$

$\therefore R_r = 80\pi^2 (\frac{d\ell}{\lambda})^2$

**Eg. Find the radiation efficiency of an isolated Hertzian dipole made of a metal wire of radius  $a$ , length  $d$ , and conductivity  $\sigma$ .**

(Sol.) The ohmic power loss is  $P_\ell = \frac{1}{2} I^2 R_\ell$ . The radiated power is  $P_r = \frac{1}{2} I^2 R_r$

$$\eta_r = \frac{P_r}{P_r + P_\ell} = \frac{1}{1 + (R_\ell / R_r)}, \quad R_\ell = R_s \left( \frac{d\ell}{2\pi a} \right),$$

$$\text{where } R_s = \sqrt{\frac{\pi f \mu_0}{\sigma}} \Rightarrow \eta_r = \frac{1}{1 + \frac{R_s}{160\pi^3} \left( \frac{\lambda}{a} \right) \left( \frac{\lambda}{d\ell} \right)}$$

Assume that  $a=1.8\text{mm}$ ,  $d\ell = 2\text{m}$ ,  $f = 1.5\text{MHz}$ , and  $\sigma = 5.80 \times 10^7 \text{ (S/m)}$

$$\lambda = \frac{c}{f} = 200\text{(m)}, \quad R_s = \sqrt{\frac{\pi \times (1.50 \times 10^6) \times (4\pi 10^{-7})}{5.80 \times 10^7}} = 3.20 \times 10^{-4} \text{ (}\Omega\text{)},$$

$$R_\ell = 3.20 \times 10^{-4} \times \left( \frac{2}{2\pi 1.8 \times 10^{-3}} \right) = 0.057 \text{ (}\Omega\text{)}, \quad R_r = 80\pi^2 \left( \frac{2}{200} \right)^2 = 0.079 \text{ (}\Omega\text{)} \quad \text{and}$$

$$\eta_r = \frac{0.079}{0.079 + 0.057} = 58\%$$

**Eg. A 1MHz uniform current flows in a vertical antenna of the length 15m. The antenna is a center-fed copper rod having a radius of 2cm. Find (a) the radiation resistance, (b) the radiation efficiency, (c) the maximum electric field intensity at a distance of 20km, the radiated power of the antenna is 1.6kW.**

(Sol.)  $\lambda = \frac{3 \times 10^8}{10^6} = 300\text{m} \gg 15\text{m} = d\ell$ ,  $a=0.02\text{m}$ ,  $\sigma_{\text{copper}}=5.8 \times 10^7$ ,

$$R_s = \sqrt{\frac{\pi f \mu_c}{\sigma_c}} = 2.6 \times 10^{-4}$$

$$\text{(a) } R_r = 80\pi^2 (15/300)^2 = 1.97\Omega, \quad \text{(b) } \eta_r = 1 / \left( 1 + \frac{R_s}{160\pi^3 (\lambda/a)(\lambda/d\ell)} \right) = 98\%$$

$$\text{(c) } P_r = \frac{I^2 (d\ell)^2}{12\pi} \eta_0 \beta^2 = 1600 \Rightarrow |E_\theta|_{\text{max}} = \left( \frac{Id\ell}{4\pi} \right) \frac{\eta_0 \beta}{R} \approx 1.9 \times 10^{-2} \text{ V/m}$$

**Eg. A time-harmonic uniform current  $I_0 \cos(\omega t)$  flows in a small circular loop of radius  $b (\ll \lambda)$  lying in the  $xy$ -plane. (a) Find the radiation resistance  $R_r$  of the magnetic dipole. (b) Obtain an expression for its radiation efficiency  $\eta_r$  if the loop is made of radius  $a$ .**

$$\text{(Sol.) (a) Duality} \Rightarrow dl \leftrightarrow \beta \pi b^2 \Rightarrow R_r = 80 \pi^2 \left( \frac{\beta \pi b^2}{\lambda} \right)^2 = 320 \pi^6 \left( \frac{b}{\lambda} \right)^4$$

$$\text{(b) } \eta_r = \frac{1}{1 + \frac{R_s}{160 \pi^3} \left( \frac{\lambda}{a} \right) \left( \frac{\lambda}{\beta \pi b^2} \right)}$$

**Eg. The amplitude of the time-harmonic current distribution on a center-fed short dipole antenna of length  $2h$  ( $h \ll \lambda$ ) can be approximated by a triangular function  $I(z) = I_0 \left( 1 - \frac{|z|}{h} \right)$ . Find (a) the far-zone electric and magnetic field intensities, (b) the radiation resistance, and (c) the directivity.**

$$\text{(Sol.) (a) } dE_\theta = \frac{jI(z)dz}{4\pi} \eta_0 \beta \sin \theta \frac{e^{-j\beta R}}{R}, R = R_0 - z \cos \theta \text{ in } e^{-j\beta R}, H_\phi \approx \frac{j\beta R}{4\pi R} I_0 e^{-j\beta R} \sin \theta$$

$$E_\theta \approx \int_{-h}^h \frac{jI_0}{4\pi} \left( 1 - \frac{|z|}{h} \right) \cdot \eta_0 \beta \sin \theta \cdot \frac{e^{-j\beta(R_0-z)}}{R_0} dz \approx \frac{jI_0}{R_0 \beta h} e^{-j\beta R_0} \sin \theta \cdot \frac{1 - \cos(\beta h \cos \theta)}{\cos^2 \theta} \approx \frac{j30 \beta h}{R} I_0 e^{-j\beta R} \sin \theta$$

$$\text{(b) } P_r = \frac{1}{2} \int_0^{2\pi} \int_0^\pi E_\theta H_\phi^* R^2 \sin \theta d\theta d\phi = \frac{I_0^2}{2} \left[ 80 \pi^2 \left( \frac{h}{\lambda} \right)^2 \right] \Rightarrow R_r = 80 \pi^2 \left( \frac{h}{\lambda} \right)^2$$

$$\text{(c) } D = \frac{4\pi |E_{\max}|^2}{\int_0^{2\pi} \int_0^\pi |E_\theta|^2 \sin \theta d\theta d\phi} = 1.5$$

### 8-3 Linear Dipole Antennas and Effective Lengths

$$\text{Assume } I(z) = I_m \sin \beta(h - |z|) = \begin{cases} I_m \sin \beta(h - z), & z > 0 \\ I_m \sin \beta(h + z), & z < 0 \end{cases}$$

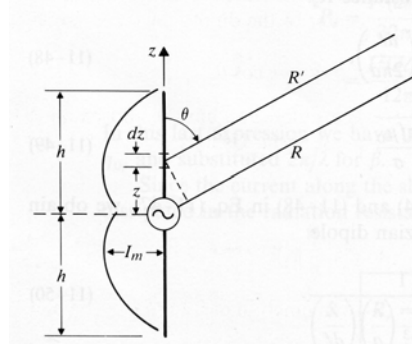

$$E_\theta = \eta_0 H_\phi = \eta_0 \int_{-h}^h \frac{I(z) dz}{4\pi R'} e^{-j\beta R'} \beta \sin \theta$$

$$(R \gg h, R' = (R^2 + z^2 - 2Rz \cos \theta)^{1/2} \approx R - z \cos \theta)$$

$$\Rightarrow E_\theta \approx j \frac{I_m \eta_0 \beta \sin \theta}{4\pi R} e^{-j\beta R} \int_{-h}^h \sin \beta(h - |z|) e^{j\beta z \cos \theta} dz = \frac{j60 I_m}{R} \cdot e^{-j\beta R} \cdot F(\theta)$$

$$\text{where } F(\theta) = \frac{\cos(\beta h \cos \theta) - \cos \beta h}{\sin \theta}$$

**Half-wave dipole:**  $2h = \lambda/2$ ,  $\beta h = \pi/2$

$$\begin{cases} E_\theta = \frac{j60 I_m}{R} e^{-j\beta R} \left\{ \frac{\cos[(\pi/2) \cos \theta]}{\sin \theta} \right\} \\ H_\phi = \frac{j I_m}{2\pi R} e^{-j\beta R} \left\{ \frac{\cos[(\pi/2) \cos \theta]}{\sin \theta} \right\} \end{cases} \Rightarrow P_{av} = \frac{1}{2} E_\theta H_\phi^* = \frac{15 I_m^2}{\pi R^2} \left\{ \frac{\cos[(\pi/2) \cos \theta]}{\sin \theta} \right\}^2$$

**Half-power beam width of a half-wave dipole:**  $\Delta\theta = \theta_1 - \theta_2 \approx 78^\circ$ , where  $\theta_1$  and  $\theta_2$  are two roots of

$$\frac{\cos((\pi/2) \cos \theta)}{\sin \theta} = \frac{1}{\sqrt{2}}$$

$$P_r = \int_0^{2\pi} \int_0^\pi P_{av} R^2 \sin \theta d\theta d\phi = 30 I_m^2 \int_0^\pi \frac{\cos^2[(\pi/2) \cos \theta]}{\sin \theta} d\theta = 36.54 I_m^2 (\text{w}) = \frac{I_m^2}{2} R_r$$

$$\Rightarrow R_r = 73.1 \Omega \text{ and } U_{\max} = R^2 P_{av}(\theta = \pi/2) = \frac{15}{\pi} I_m^2 \Rightarrow D = \frac{4\pi U_{\max}}{P_r} = 1.64 > 1.5$$

**Radiation patterns of linear dipoles:**

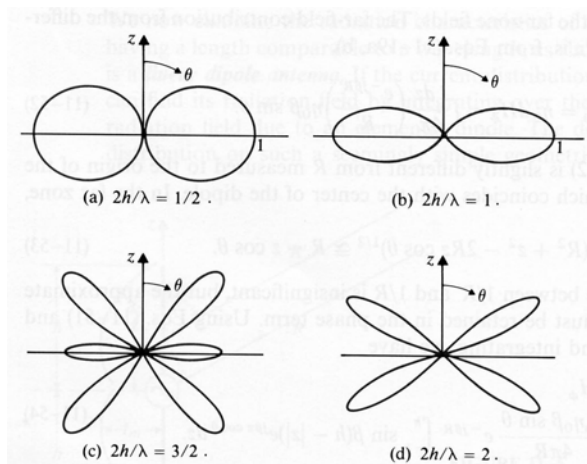

E-plane radiation patterns for center-fed dipole antennas

**Effective length** of a transmitting linear dipole antenna,  $l_e(\theta)$ :

$$E_\theta = \eta_0 H_\phi = j \frac{I_m \eta_0 \beta \sin \theta}{4\pi R} e^{-j\beta R} \int_{-h}^h \sin \beta(h-|z|) e^{j\beta z \cos \theta} dz = \frac{j30}{R} \beta e^{-j\beta R} \left\{ \sin \theta \int_{-h}^h I(z) e^{j\beta z \cos \theta} dz \right\}$$

$$= \frac{j30I(0)}{R} \beta e^{-j\beta R} \ell_e(\theta), \text{ where } \ell_e(\theta) = \frac{\sin \theta}{I(0)} \int_{-h}^h I(z) e^{j\beta z \cos \theta} dz \text{ is the effective length.}$$

Maximum of  $l_e(\theta)$  occurs when  $\theta=\pi/2 \Rightarrow l_e(\theta=\pi/2) = \frac{1}{I(0)} \int_{-h}^h I(z) dz$

**Note:**  $l_e = -V_{oc}/E_i$  is the effective length of a receiving linear dipole antenna = that of transmitting one.

**Eg. Assume a sinusoidal current distribution on a center-fed, thin, straight half-wave dipole. Find its effective length. What is its maximum value?**

(Sol.)  $I(0)=I_m, h=\lambda/4,$

$$\ell_e(\theta) = \frac{\sin \theta}{I(0)} \int_{-\lambda/4}^{\lambda/4} I_m \sin \beta \left( \frac{\lambda}{4} - |z| \right) e^{j\beta z \cos \theta} dz = \frac{2}{\beta} \left[ \frac{\cos(\frac{\pi}{2} \cos \theta)}{\sin \theta} \right], \quad \ell_e \left( \frac{\pi}{2} \right) = \frac{2}{\beta} = \frac{\lambda}{\pi}$$

**Eg. A 1.5MHz uniform plane wave having a peak electric field intensity  $E_0$  is incident on a half-wave dipole at an angle  $\theta$ . (a) Find the expression for the open-circuit voltage  $V_{oc}$  at the terminals of the dipole. (b) If the dipole is connected to a matched load, what is the maximum power  $P_L$  delivered to the load?**

(Sol.) (a)  $V_{oc} = -E_0 \ell_e = -\frac{\lambda E_0}{\pi} \left[ \frac{\cos(\frac{\pi}{2} \cos \theta)}{\sin \theta} \right], \quad \lambda = 200m$

(b)  $P_L = \frac{1}{2} \left| \frac{V_{oc}}{R_r + R_L} \right|^2 R_L = \frac{V_{oc}^2}{8R_r}$

**Eg. The transmitting antenna of a radio navigation system is a vertical metal mast 40m in height insulated from the earth. A 180kHz source sends a current having an amplitude of 100A into the base of the mast and the earth to be a perfectly conducting plane, determine: (a) the effective length of the antenna (b) the maximum field intensity at a distance 160km from the antenna (c) the total radiated power.**

(Sol.) (a)  $\ell_e = \frac{1}{I_0} \int_0^h I_0 \left(1 - \frac{z}{h}\right) dz = \frac{h}{2} = 20m,$  (b)  $|E_\theta|_{\max} = \frac{I_0}{4\pi R} \eta_0 \beta \times 2\ell_e = \frac{30I_0 \beta h}{R}$

(c)  $P_r = \frac{1}{2} \int_0^{\pi/2} \frac{|E_\theta|^2}{\eta_0} 2\pi R^2 \sin \theta d\theta = \frac{2\pi}{3} \eta_0 \left( \frac{I_0 \beta h}{4\pi} \right)^2 = 1.14kW$



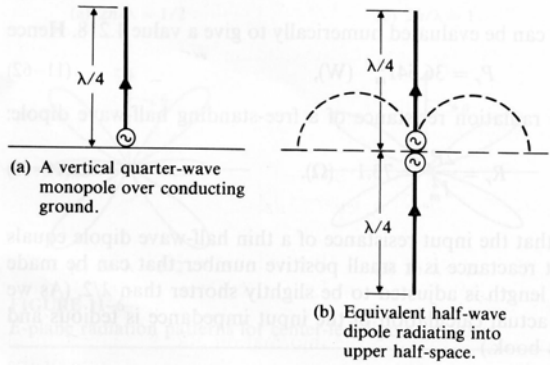

**Monopole antenna:**  $P_r = 18.27 I_m^2 W$ , and  $R_r = 2P_r / I_m^2 = 36.54 \Omega$  is exactly one-half of the radiation resistance of a half-wave antenna in the free space.  $D = 2\pi U_{\max} / P_r = 1.64$  is the same as the directivity of a half-wave antenna.

### 8-4 Traveling-wave Antenna

$$I(z) = I_0 e^{-j\beta z}, \quad dE_0 = j \frac{Idz}{4\pi r} \left( \frac{e^{-j\beta R}}{R} \right) \eta_0 \beta \sin \theta \quad \text{for a small dipole } Idz$$

$$E_\theta = \frac{j\eta_0 \beta \sin \theta}{4\pi r} e^{-j\beta R} \int_0^L I(z) e^{j\beta z \cos \theta} dz = \frac{j60 I_0}{R} e^{-j\beta[R+(L/2)(1-\cos \theta)]} F(\theta), \quad \text{where}$$

$$F(\theta) = \frac{\sin \theta \sin[\beta L(1 - \cos \theta) / 2]}{1 - \cos \theta}$$

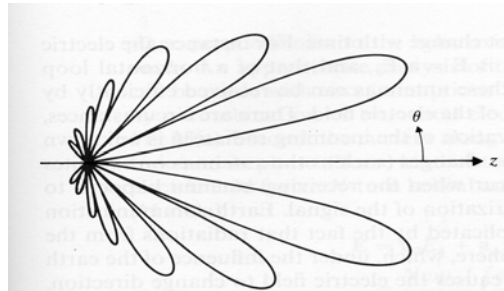
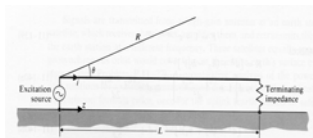

Some examples of coplanar antennas (by H. -C. Chen and Dr. I-Fong Chen):

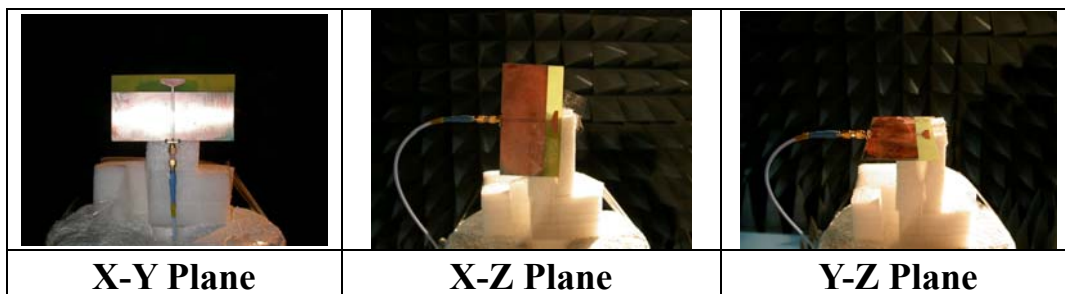
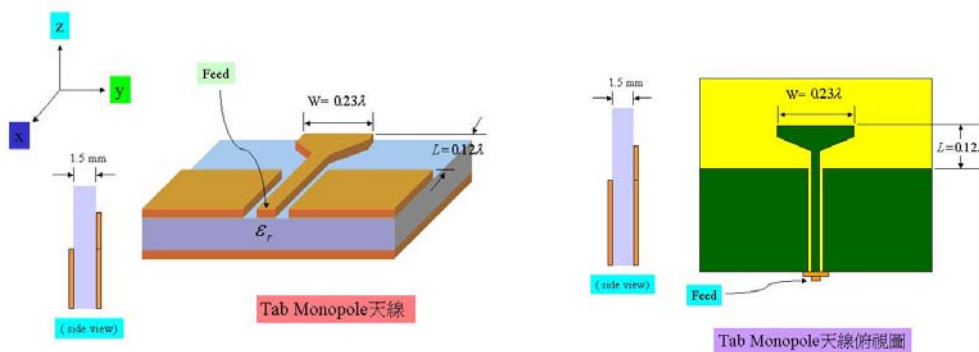

Test Result

Freq. (MHz)	X-Y Plane		X-Z Plane		Y-Z Plane	
	Vertical	Horizontal	Vertical	Horizontal	Vertical	Horizontal
2400	1.87	1.71	-10.04	-0.42	-12.74	2.26
2450	1.66	1.14	-10.00	-0.80	-13.37	1.55
2500	1.47	0.88	-10.42	-0.09	-13.68	1.93

Unit : dBi

2.4G~2.5GHz 的量測結果表

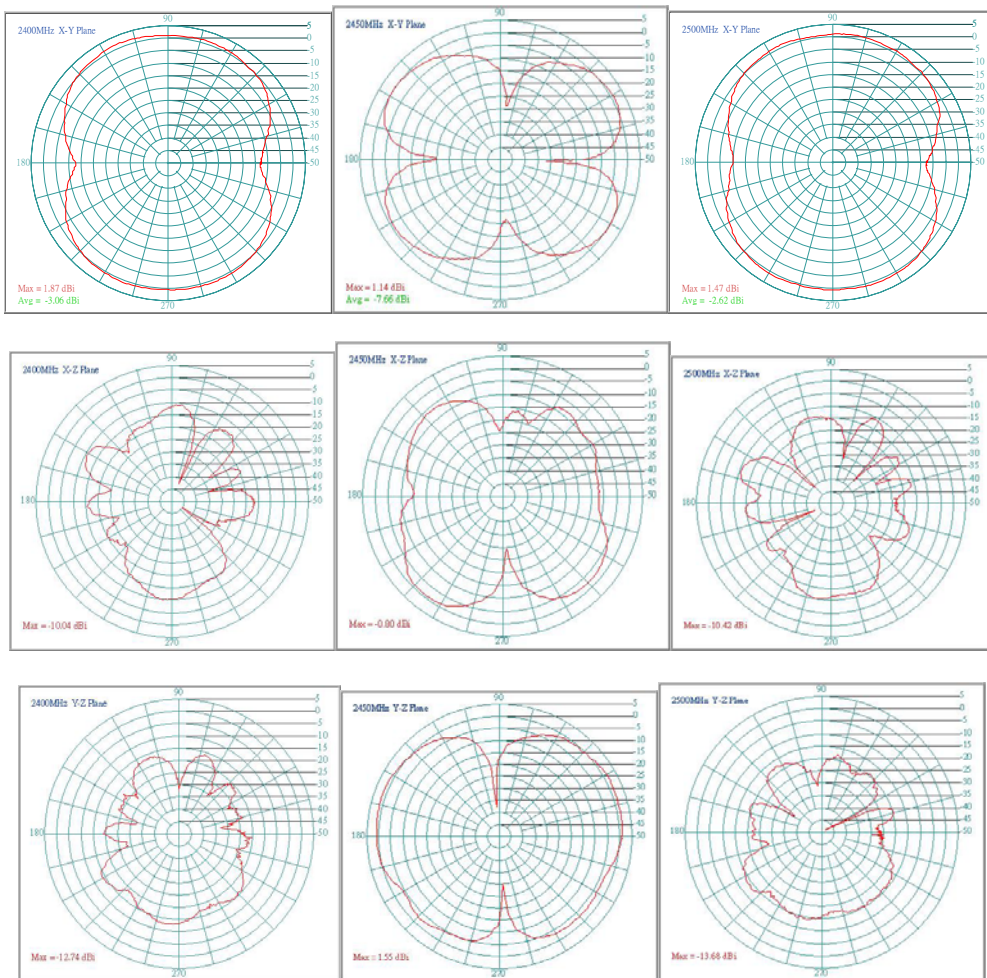

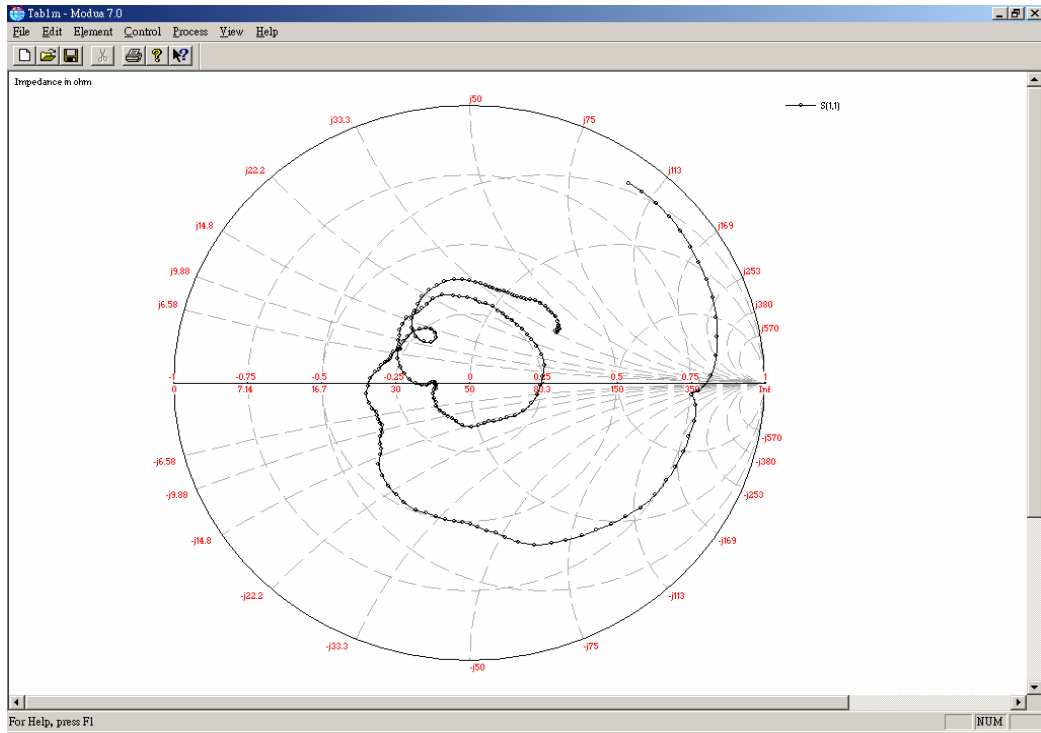

The Impedance of the Tab Monopole in the Smith Chart

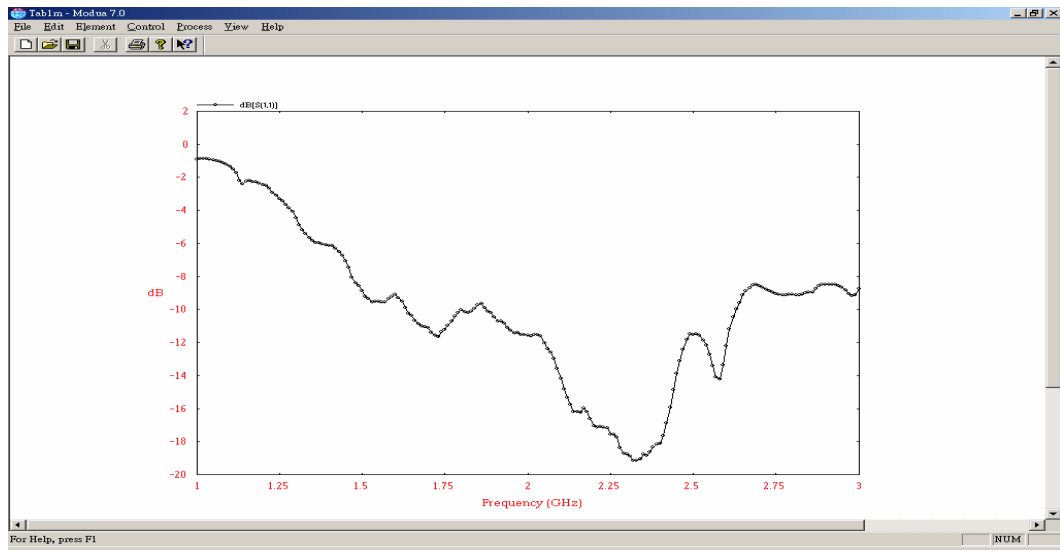

The S<sub>11</sub> parameter of the Tab Monopole

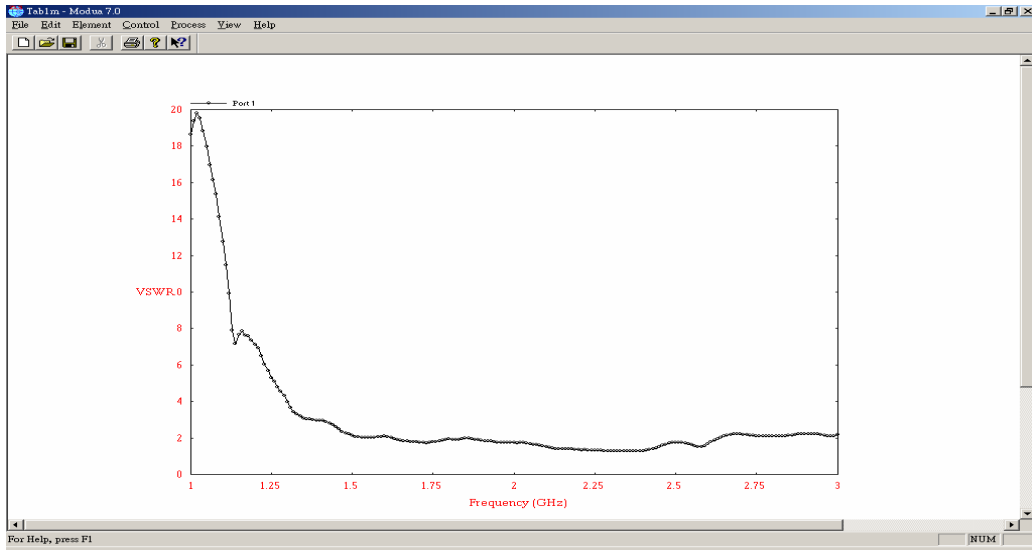

The VSWR of Tab Monopole

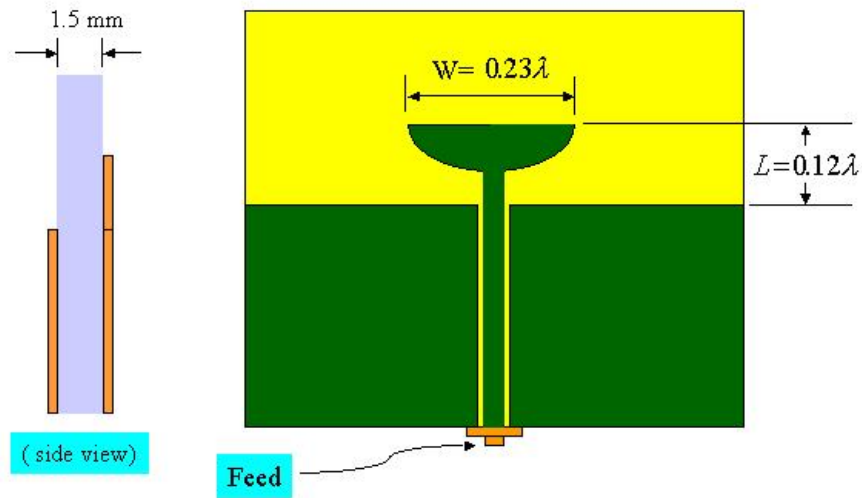

半圓型輻射體之Tab Monopole天線俯視圖

Test Result

Freq. (MHz)	X-Y Plane		X-Z Plane		Y-Z Plane	
	Vertical	Horizontal	Vertical	Horizontal	Vertical	Horizontal
2400	1.57	1.30	-13.78	-0.76	-13.11	1.81
2450	1.24	0.84	-12.96	-0.87	-10.89	1.41
2500	1.10	1.31	-11.09	-0.43	-11.79	0.86

Unit : dBi

2.4G~2.5GHz 的量測結果表

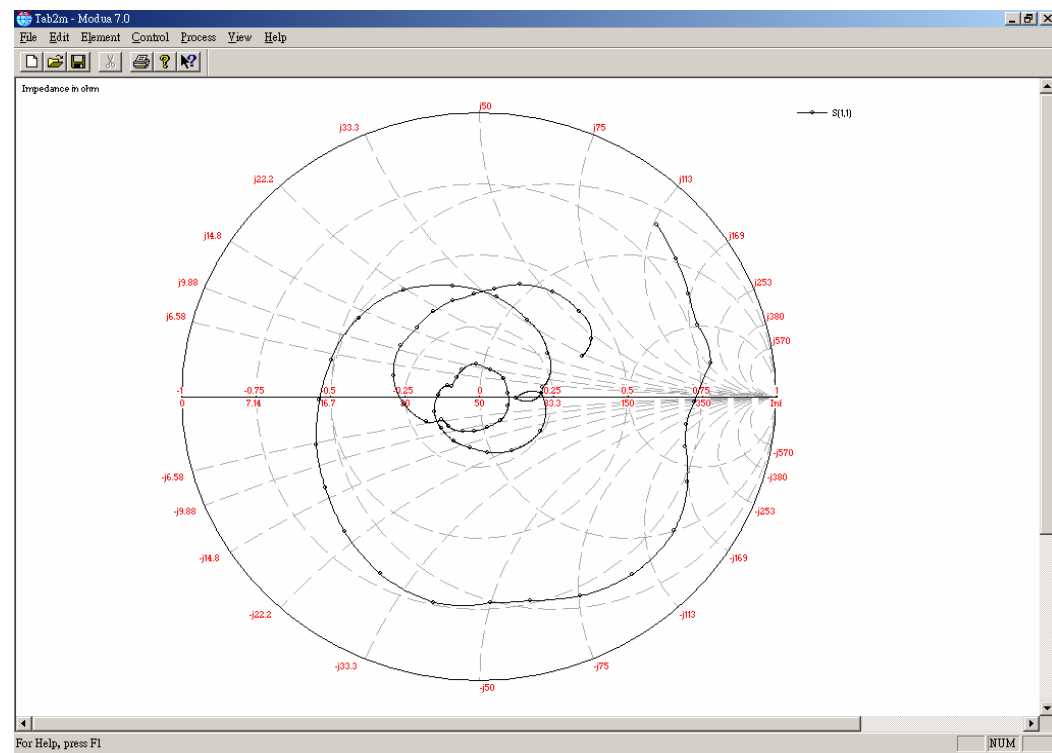
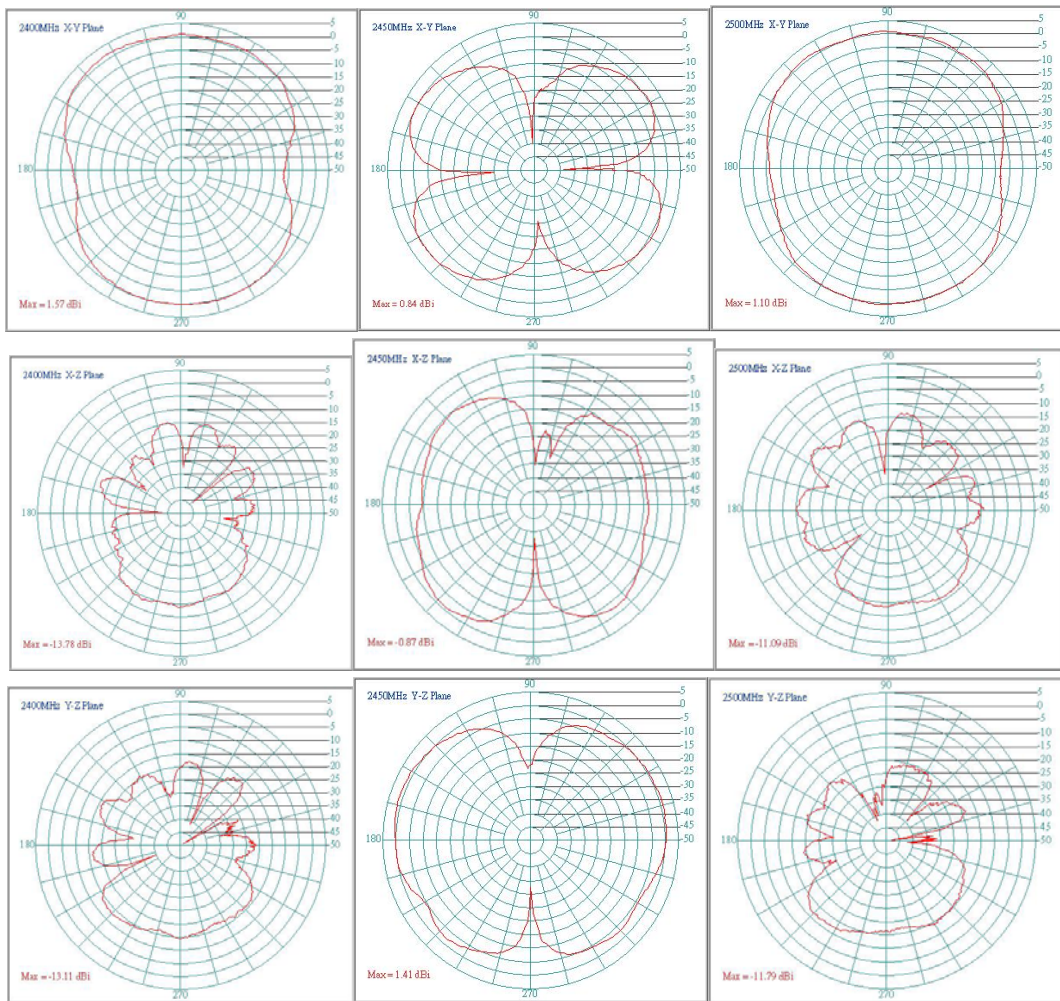

The Impedance of the Semi-Circular Tab Monopole in the Smith Chart



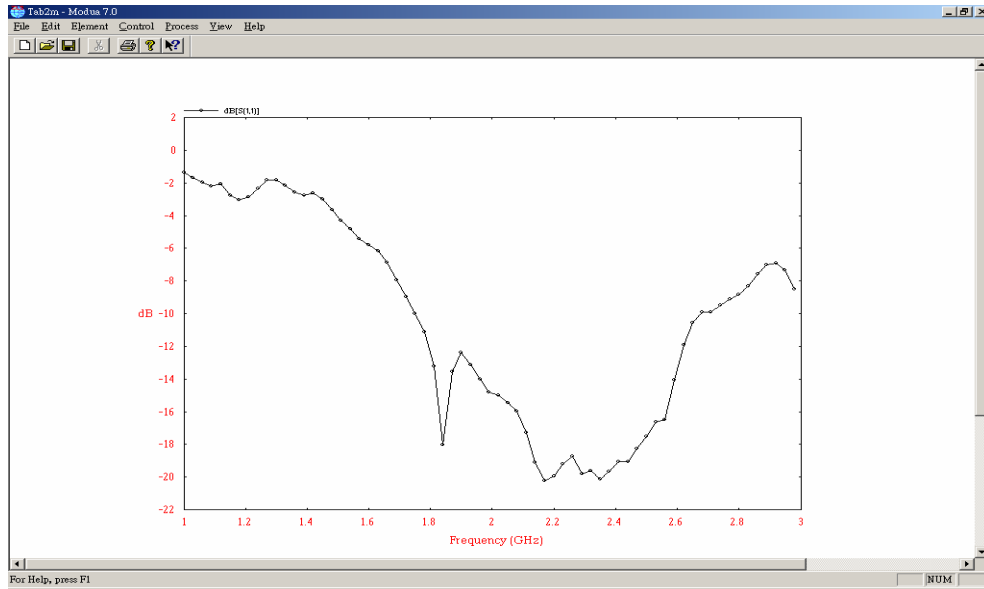

The  $S_{11}$  parameter of the Semi-Circular Tab Monopole

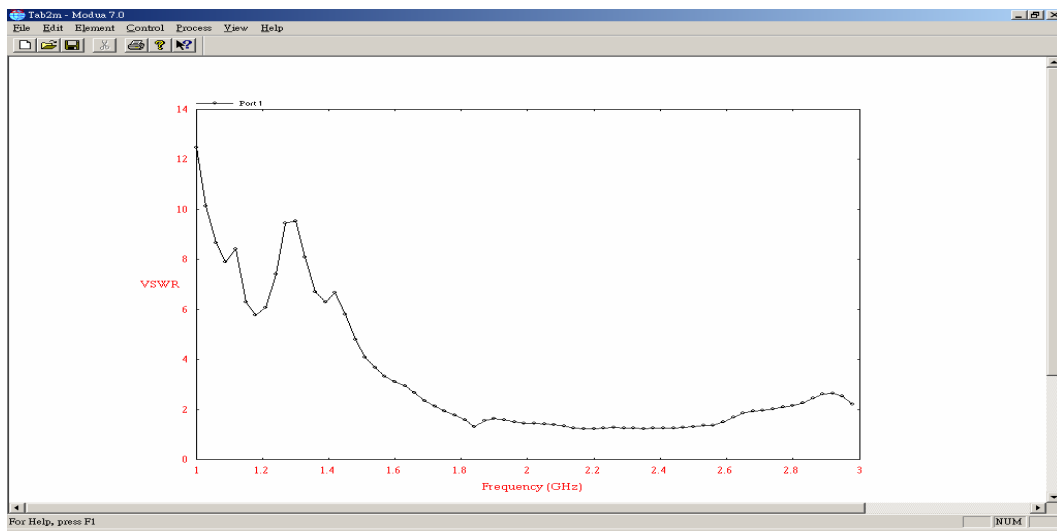

The VSWR of the Semi-Circular Tab Monopole

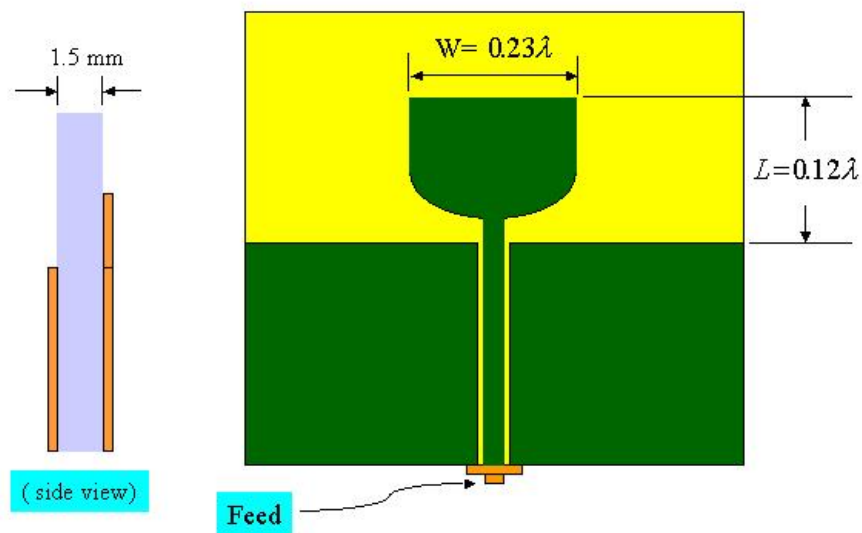

酒杯型輻射體之Tab Monopole天線俯視圖

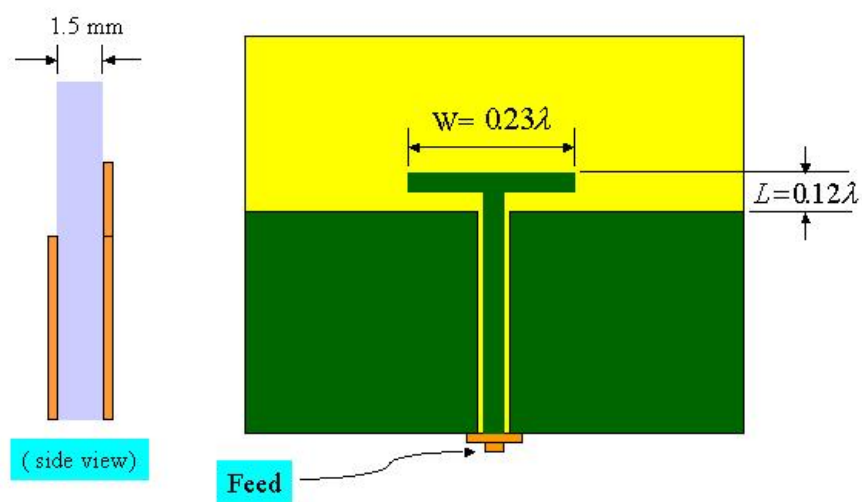

T型輻射體之Tab Monopole天線俯視圖



## 8-5 Helical Antenna

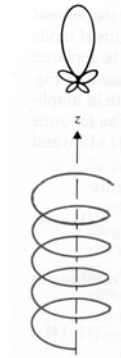
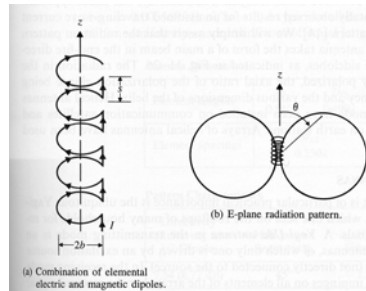
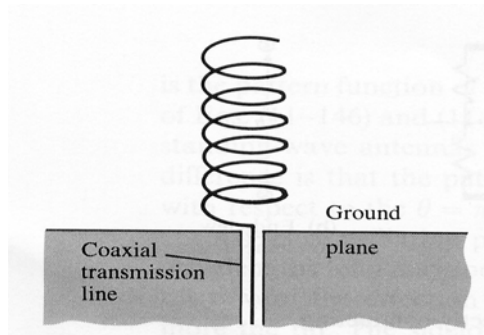

Normal mode ( $s, 2b \ll \lambda$ ): Its behavior is like an electric dipole

Axial mode ( $s, 2b \approx \lambda$ ): Its mainbeam placed in the endfire direction.

$$\vec{E} = \hat{a}_\theta E_\theta + \hat{a}_\phi E_\phi = \frac{N\omega\mu_0 I}{4\pi} \left(\frac{e^{-j\beta R}}{R}\right) (\hat{a}_\theta js + \hat{a}_\phi \beta\pi b^2) \sin\theta : \text{Elliptically-polarized.}$$

If  $s = \beta\pi b^2$  or  $b = \frac{1}{\pi} \sqrt{\frac{s\lambda}{2}}$ , it becomes circularly-polarized.

**Eg. A helical antenna operating in the normal mode has  $N$  turns with diameter  $2b$  and interturn spacing  $s$ . Both  $2b$  and  $s$  are very small in comparison to  $\lambda/N$  and are adjusted to radiate circularly polarized waves. Find (a) its directive gain and directivity, (b) its radiation resistance.**

$$\text{(Sol.) (a) } \vec{E} = \frac{N\omega\mu_0 I}{4\pi} \left(\frac{e^{-j\beta R}}{R}\right) [\hat{a}_\theta js + \hat{a}_\phi \beta\pi b^2] \sin\theta, \quad \vec{H} = \frac{1}{\eta_0} \hat{a}_R \times \vec{E} = \frac{N\beta I}{4\pi} \left(\frac{e^{-j\beta R}}{R}\right) [\hat{a}_\phi js - \hat{a}_\theta \beta\pi b^2] \sin\theta$$

Circularly polarized:  $s = \beta\pi b^2$ ,

$$U = R^2 \hat{a}_R \cdot P_{av} = R^2 \hat{a}_R \cdot \frac{1}{2} \text{Re}[\vec{E} \times \vec{H}] = \frac{\beta^2 \eta_0}{16\pi^2} (NIS)^2 \sin^2 \theta$$

$$P_r = \int_0^{2\pi} \int_0^\pi U \sin\theta d\theta d\phi = \frac{\beta^2 \eta_0}{b\pi} (NIS)^2 \Rightarrow G_D = \frac{4\pi U}{P_r} = \frac{3}{2} \sin^2 \theta, \quad D = G_D \left(\frac{\pi}{2}\right) = 1.5$$

$$\text{(b) } R_r = \frac{2P_r}{I^2} = \frac{\eta_0 (NIS)^2}{3\pi} = 40(N\beta^2 \pi b^2)^2$$

**Note:** Receiving antenna's pattern is identical with transmitting one's.

## 8-6 Antenna Arrays

**Two-element antenna array:** (In case of no coupling between antennas)

$$R_1 \cong R_0 - d \sin \theta \cos \phi$$

$$E = E_0 + E_1 = E_m F(\theta, \phi) \left[ \frac{e^{-j\beta R_0}}{R_0} + \frac{e^{j\xi} e^{-j\beta R_1}}{R_1} \right]$$

$$= E_m \frac{F(\theta, \phi)}{R_0} e^{-j\beta R_0} [1 + e^{j\beta d \sin \theta \cos \phi} e^{j\xi}]$$

$$= E_m \frac{F(\theta, \phi)}{R_0} e^{-j\beta R_0} e^{j\psi/2} (2 \cos \frac{\Psi}{2}), \text{ where } \Psi = \beta d \sin \theta \cos \phi + \xi$$

$$\Rightarrow |E| = \frac{2E_m}{R_0} |F(\theta, \phi)| \cdot \left| \cos \frac{\Psi}{2} \right| = \text{Element Factor} \times \text{Array Factor}$$

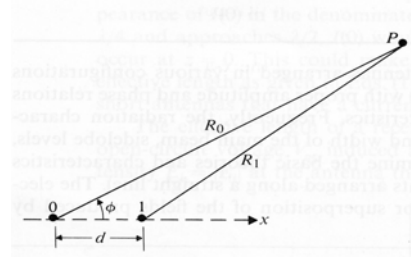

**Eg. Plot the H-plane radiation patterns of two parallel dipoles for the following two cases: (a)  $d = \lambda/2, \xi = 0$ , (b)  $d = \lambda/4, \xi = -\pi/2$ .**

(Sol.) Let the dipole is z-directed

$$\text{In the H-plane } (\theta = \pi/2): |A(\phi)| = \left| \cos \frac{\Psi}{2} \right| = \left| \cos \frac{1}{2} (\beta d \cos \phi + \xi) \right|$$

$$\text{(a) } |A(\phi)| = \left| \cos \left( \frac{\pi}{2} \cos \phi \right) \right|, \text{ (b) } |A(\phi)| = \left| \cos \frac{\pi}{4} (\cos \phi - 1) \right|$$

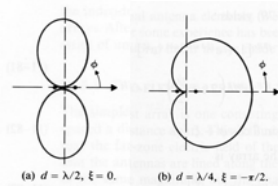

## General Uniform Linear Arrays:

**Normalized array factor in the xy-plane ( $\theta = \pi/2$ ):**

$$|A(\Psi)| = \frac{1}{N} |1 + e^{j\Psi} + e^{j2\Psi} + \dots + e^{j(N-1)\Psi}|$$

$$= \frac{1}{N} \left| \frac{1 - e^{jN\Psi}}{1 - e^{j\Psi}} \right| = \frac{1}{N} \left| \frac{\sin(N\Psi/2)}{\sin(\Psi/2)} \right|, \text{ where } \Psi = \beta d \sin(\theta) \cos \phi + \xi = \beta d \cos \phi + \xi \text{ if } \theta = \pi/2$$

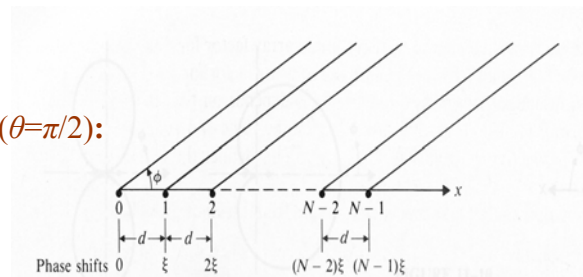

**Mainbeam direction,  $\phi_0$ :**  $\because$  Max at  $\Psi = 0, \therefore \beta d \cos \phi_0 + \xi = 0 \Rightarrow \cos \phi_0 = \frac{-\xi}{\beta d}$

**Null locations:**  $\frac{N\Psi}{2} = \pm k\pi, k=1, 2, 3, \dots$

**Sidelobe locations:**  $\frac{N\Psi}{2} = \pm(2m+1)\frac{\pi}{2}, m=1, 2, 3, \dots$

The first sidelobe level:  $\frac{N\Psi}{2} = \pm \frac{3\pi}{2}$ ,  $|A(\Psi)| = \frac{1}{N} \left| \frac{1}{\sin(2\pi/3N)} \right| = 0.212$  (as  $N \rightarrow \infty$ )

**Broadside array** ( $\phi_0 = \pm \frac{\pi}{2}, \xi = 0$ ):  $|E_{\max}|$  occurs at a direction  $\perp$  the line of arrays.

**Endfire array** ( $\phi_0 = 0, \xi = -\beta d$ ):  $|E_{\max}|$  occurs at a direction  $//$  the line of arrays.

**Beamwidth between two first nulls:**  $\frac{N\Psi_1}{2} = \pi, \frac{N\Psi_2}{2} = -\pi \Rightarrow \Psi_1 - \Psi_2 = \frac{4\pi}{N}$

$$2\Delta\phi \Rightarrow (\beta d \cos \phi_1 + \xi) - (\beta d \cos \phi_2 + \xi) = \beta d (\cos \phi_1 - \cos \phi_2) = \frac{4\pi}{N}$$

Let  $\phi_1 = \phi_0 + \Delta\phi$ ,  $\phi_2 = \phi_0 - \Delta\phi$

( $\phi_0 = \frac{\pi}{2}$ )  $\Rightarrow \Delta\phi = \sin^{-1}\left(\frac{\lambda}{Nd}\right)$  for a broadside array.

( $\phi_0 = 0$ )  $\Rightarrow \Delta\phi \approx \sqrt{\frac{2\lambda}{Nd}}$  for an endfire array.

**Eg. For a uniform linear array of 12 elements spaced  $\lambda/2$  apart. Sketch the normalized array pattern  $|A(\Psi)|$ .**

$$\text{(Sol.) } d = \frac{\lambda}{2}, \beta d = \pi, |A(\Psi)| = \frac{1}{N} \left| \frac{\sin(N\Psi/2)}{\sin(\Psi/2)} \right| = \frac{1}{12} \left| \frac{\sin(6\Psi)}{\sin(\Psi/2)} \right|$$

Endfire  $\Rightarrow \xi = -\pi, \Psi = \beta d \cos \phi + \xi = \pi \cos \phi - \pi = \pi(\cos \phi - 1)$

Broadside  $\Rightarrow \xi = 0, \Psi = \beta d \cos \phi + \xi = \pi \cos \phi$

$$\text{Half-power point: } \frac{\sin(6\Psi)}{12\sin(\Psi/2)} = \frac{1}{\sqrt{2}} \Rightarrow 2\Delta\phi = \begin{cases} 9.55(\lambda/d) & \text{degree for endfire array} \\ 46.78\sqrt{\lambda/d} & \text{degree for broadside array} \end{cases}$$

**Eg. Consider a five-element broadside binomial array. (a) Determine the relative excitation amplitudes in the array elements. (b) Plot the array factor for  $d=\lambda/2$ . (c) Determine the half-power beamwidth and compare it with that of a five-element uniform array having the same element spacings.**

(Sol.) 1:4:6:4:1, broadside  $\Rightarrow \xi = 0$

$$\text{(a) } |A(\Psi)| = \frac{1}{16} |1 + 4e^{j\Psi} + 6e^{j2\Psi} + 4e^{j3\Psi} + e^{j4\Psi}| = \frac{1}{16} |6 + 8\cos \Psi + 2\cos 2\Psi|, \text{ where}$$

$$\Psi = \beta d \cos \phi + \xi$$

$$\text{(b) } d = \frac{\lambda}{2}, \beta d = \pi, \text{ and } \xi = 0 \Rightarrow |A(\Psi)| = \frac{1}{4} [1 + \cos(\pi \cos \phi)]^2$$

$$\text{(c) } \frac{1}{4} [1 + \cos(\pi \cos \phi)]^2 = \frac{1}{\sqrt{2}}, \phi = 74.86^\circ, \therefore 2\Delta\phi = 2(90^\circ - 74.86^\circ) = 30.28^\circ$$

**Phased Array:**  $\because \cos \phi_0 = \frac{-\xi}{\beta d}$ ,  $\therefore$  Vary  $\xi$  electrically  $\Rightarrow$  Vary  $\phi_0$  (the direction of the main beam). It can be utilized as a military radar system to scan and track a target.



**Eg. Draw the far-field pattern of a phased array of dipoles with  $N=5$ ,  $d=\lambda/2$ .**

(Sol.) The effective scan range is about from  $\phi_0 = 60^\circ$  to  $\phi_0 = 120^\circ$  as follows.

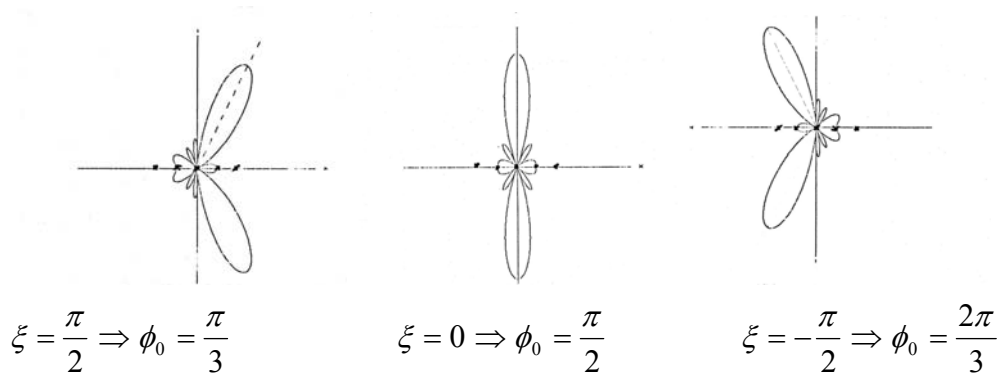

**Eg. Obtain the pattern function of a uniformly excited rectangular array of  $N_1 \times N_2$  parallel half-wave dipoles. Assume that the dipoles are parallel to the  $z$ -axis and their centers are spaced  $d_1$  and  $d_2$  apart in the  $x$ - and  $y$ -directions, respectively.**

(Sol.) 
$$F(\theta, \phi) = \left| \frac{\cos(\frac{\pi}{2} \cos \theta)}{\sin \theta} \right| \cdot |A_x(\Psi_x)| \cdot |A_y(\Psi_y)|$$
, where  $|A_x(\Psi_x)| = \frac{1}{N_1} \left| \frac{\sin(\frac{N_1 \Psi_x}{2})}{\sin(\frac{\Psi_x}{2})} \right|$ ,

$$|A_y(\Psi_y)| = \frac{1}{N_2} \left| \frac{\sin(\frac{N_2 \Psi_y}{2})}{\sin(\frac{\Psi_y}{2})} \right|, \quad \Psi_x = \frac{\beta d_1}{2} \sin \theta \cos \phi + \xi_x, \text{ and}$$

$$\Psi_y = \frac{\beta d_2}{2} \sin \theta \cos \phi + \xi_y$$

An example of microstrip linear antenna array (by Dr. I-Fong Chen):

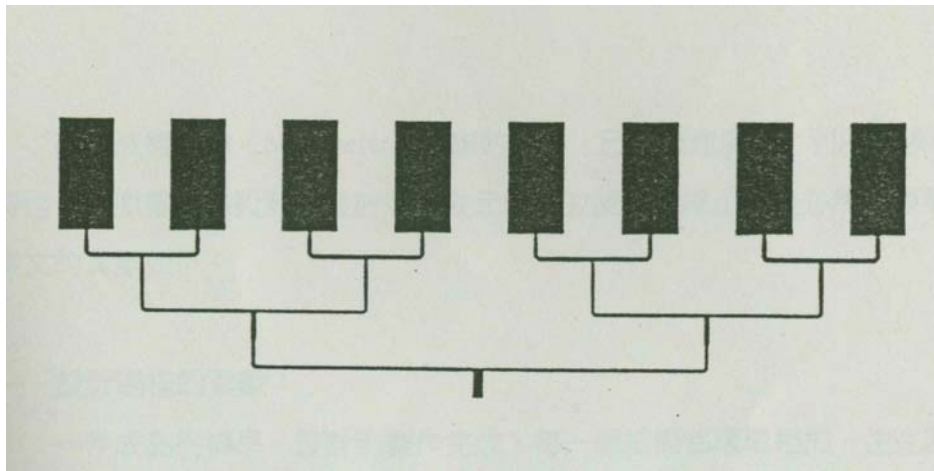

Characteristics:

式	型	FPA10000 (HEXAWAVE)	BCFPA (PROTOTYPE)
功能			
接收範圍		10.7GHZ	11.431GHZ
駐波比		2.5	2
波束寬		65.7°	46°
增益		>50 (dB)	>47 (dB)
本地振盪頻率		10.7±0.0015 (GHZ)	11.431±0.048 (GHZ)
體積		54×54×6.5 (cm)	12.65×4.74×0.5 (cm)
特性阻抗		75Ω	50Ω
型式		Active	Passive
指向性		10.4 (dB)	11.9 (dB)

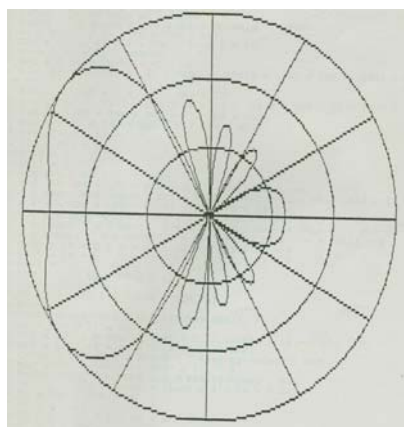

An example of smart 4-beam phased antenna array: (by W. -R. Li and Dr. K. -H. Lin)

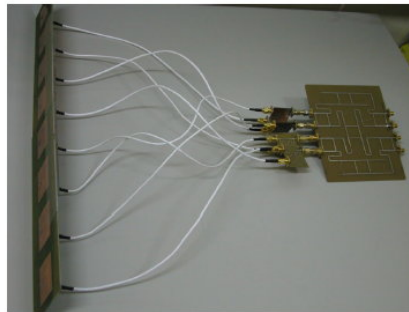

四波束切换式阵列天线

Design of  $n \times m$  Butler matrix:

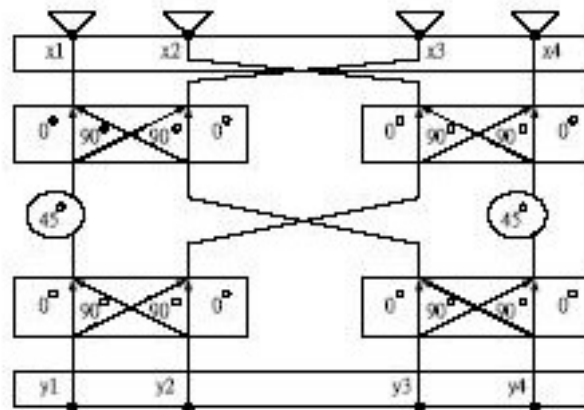
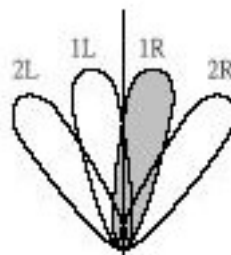

4x4巴特勒矩阵电路图

表 4x4巴特勒矩阵之元素相位分布和波束方向分布表格

	元素 x1	元素 x2	元素 x3	元素 x4	元素间的电 流相位差	波束的正向角 $\theta$ (boresight angle)
Y1	$-45^\circ$	$-90^\circ$	$-135^\circ$	$-180^\circ$	$-45^\circ$	$14.5^\circ$ (1R)
Y2	$-135^\circ$	$0^\circ$	$-225^\circ$ ( $135^\circ$ )	$-90^\circ$	$135^\circ$	$-48.6^\circ$ (2L)
Y3	$-90^\circ$	$-225^\circ$ ( $135^\circ$ )	$0^\circ$	$-135^\circ$	$-135^\circ$	$48.6^\circ$ (2R)
Y4	$-180^\circ$	$-135^\circ$	$-90^\circ$	$-45^\circ$	$45^\circ$	$-14.5^\circ$ (1L)



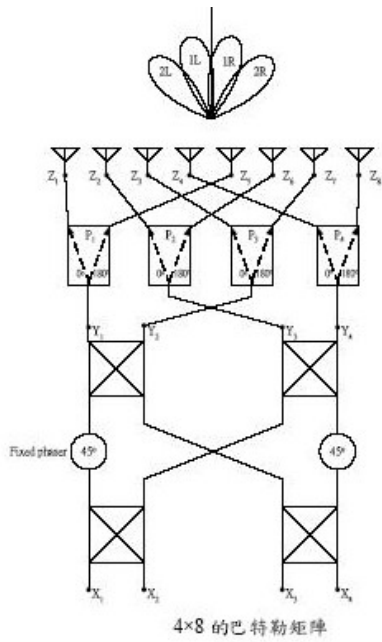

4x8巴特勒矩阵输出端的激发电流大小

$Z_1$	1
$Z_2$	1.139
$Z_3$	1.509
$Z_4$	1.724
$Z_5$	1.724
$Z_6$	1.509
$Z_7$	1.139
$Z_8$	1

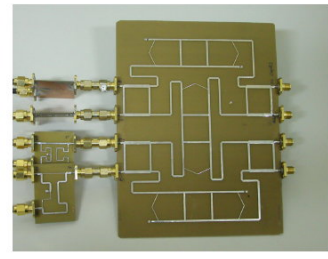
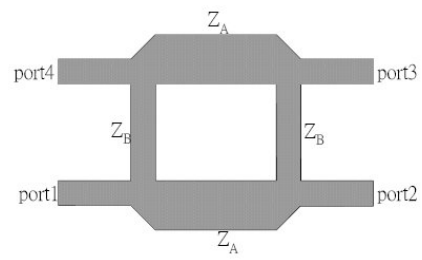

4x8 的巴特勒矩阵电路板

**Patterns:**

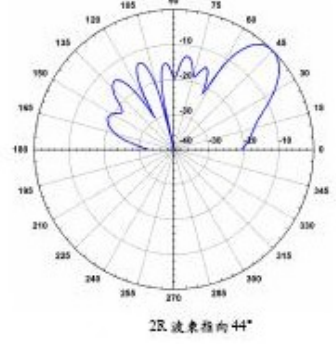
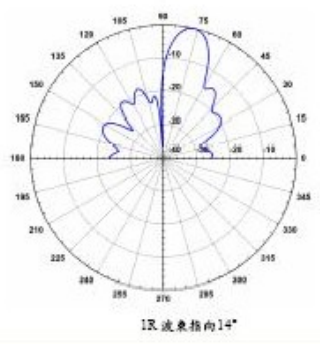
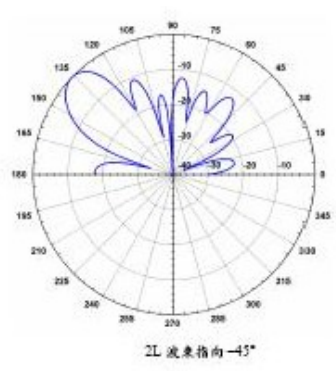
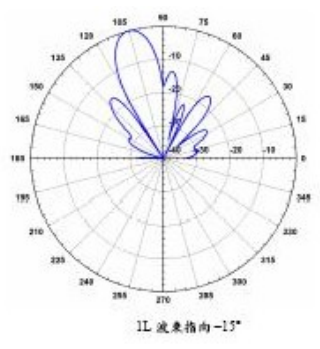

**Yagi-Uda Antenna: A kind of endfire array.**

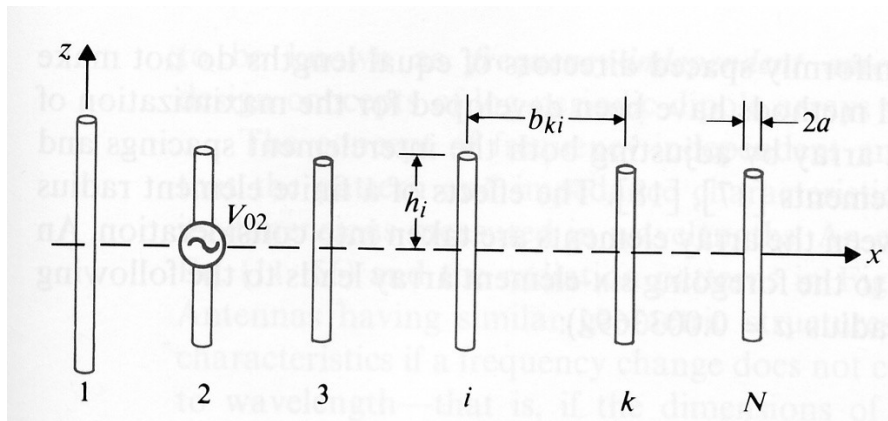

Two types:

**Antenna Dimensions**

Element lengths	$2h_1$ $0.510\lambda$	$2h_2$ $0.490\lambda$	$2h_3 = 2h_4 = 2h_5 = 2h_6$ $0.430\lambda$
Element spacings	$b_{12}$ $0.250\lambda$		$b_{23} = b_{34} = b_{45} = b_{56}$ $0.310\lambda$

**Pattern Characteristics**

Directivity (Referring to $\lambda/2$ Dipole)	Half-power Beamwidth	First Sidelobes	Front-to-back Ratio
7.54 (8.77 dB)	$45^\circ$	-7.2 (dB)	9.52 (dB)

The directivity of a half-wave dipole is 1.64 or 2.15 (dB)

**Antenna Dimensions**

Element lengths	$2h_1$ $0.476\lambda$	$2h_2$ $0.452\lambda$	$2h_3$ $0.436\lambda$	$2h_4$ $0.430\lambda$	$2h_5$ $0.434\lambda$	$2h_6$ $0.430\lambda$
Element spacings	$b_{12}$ $0.250\lambda$	$b_{23}$ $0.289\lambda$	$b_{34}$ $0.406\lambda$	$b_{45}$ $0.323\lambda$	$b_{56}$ $0.422\lambda$	

**Pattern Characteristics**

Directivity (Referring to $\lambda/2$ -Dipole)	Half-power Beamwidth	First Sidelobes	Front-to-back Ratio
13.36 (12.58 dB)	$37^\circ$	-10.9 (dB)	10.04 (dB)



## 8-7 Effective Areas of Antennas and Gains

**Effective area:**  $A_e = P_L / P_{av}$  or  $P_L = A_e P_{av}$

**Relation between the gain and the effective area:**

$$P_{av} = \frac{P_t}{4\pi r^2} G_{DA} \Rightarrow \frac{P_L}{P_t} = \frac{A_{eB} G_{DA}}{4\pi r^2}, \text{ and } \frac{G_{DA}}{A_{eA}} = \frac{G_{DB}}{A_{eB}} \text{ for all antennas}$$

**Eg. Determine the effective area,  $A_e(\theta)$ , of an elemental electric dipole of a length  $d\ell$  ( $\ll \lambda$ ) used to receive an incident plane electromagnetic wave of wavelength.**

$$\text{(Sol.) } A_e(\theta) = \frac{P_L}{P_{av}} = \frac{\eta_0}{4R_r} (d\ell)^2 \sin^2 \theta = \frac{3}{8\pi} (\lambda \sin \theta)^2 \because G_D(\theta, \phi) = \frac{3}{2} \sin^2 \theta,$$

$$\therefore \frac{(3/2) \sin^2 \theta}{(3/8\pi)(\lambda \sin \theta)^2} = \frac{G_D(\theta, \phi)}{A_e(\theta, \phi)} = \frac{4\pi}{\lambda^2} \Rightarrow G_D(\theta, \phi) = \frac{4\pi}{\lambda^2} A_e(\theta, \phi)$$

$$\text{Under matched condition: } P_L = \frac{V_{oc}^2}{8R_r} = \frac{(-\ell_e E_i)^2}{8R_r} \text{ and } P_{av} = \frac{E_i^2}{2\eta_0}$$

$$\Rightarrow A_e(\theta) = \frac{30\pi}{R_r} \ell_e^2(\theta)$$

**Eg. Assume that a linearly polarized plane electromagnetic wave is incident on a half-wave dipole, (a) obtain an expression for the effective area  $A_e(\theta)$ . (b) Calculate the maximum value of  $A_e$  for 100MHz.**

$$\text{(Sol.) (a) For a half-wave dipole, } \ell_e(\theta) = \frac{2}{\beta} \left[ \frac{\cos[(\pi/2) \cos \theta]}{\sin \theta} \right]$$

$$\Rightarrow A_e(\theta) = \frac{30\pi}{R_r} \ell_e^2(\theta) = \frac{30\pi}{73.1} \ell_e^2 = 1.28 \ell_e^2(\theta) = 0.129 \lambda^2 \left[ \frac{\cos[(\pi/2) \cos \theta]}{\sin \theta} \right]^2$$

$$\text{(b) } \beta = \frac{2\pi \times 100 \times 10^6}{3 \times 10^8} = \frac{2\pi}{3}, \quad \frac{2}{\beta} = \frac{3}{\pi}, \quad \frac{dA_e(\theta)}{d\theta} = 0 \Rightarrow \theta_{\max} = \frac{\pi}{2}, \quad A_e(\theta = \frac{\pi}{2}) = 1.17 \text{ cm}^2$$

## 8-8 Friis Transmission Formula and Radar Equation

### Friis transmission formula:

Define  $\sigma_{bs}$  = radar cross section of target,

$$\frac{P_L}{P_t} = \left(\frac{A_{e2}}{4\pi r^2}\right) G_{D1} = \frac{A_{e2}}{4\pi r^2} \cdot \frac{4\pi A_{e1}}{\lambda^2} = \frac{A_{e1} A_{e2}}{r^2 \lambda^2} = \frac{G_{D1} G_{D2} \lambda^2}{(4\pi r)^2}$$

**Eg. Communication is to be established between two stations 1.5km apart that operate at 300MHz. Each is equipped with a half-wave dipole. (a) If 100W is transmitted from one station, how much power is received by a matched load at the other station? (b) Repeat (a) assuming that both antennas are Hertzian dipoles.**

(Sol.) (a)  $\frac{P_L}{P_t} = \frac{G_{D1} G_{D2} \lambda^2}{16\pi^2 r^2}$ . Half-wave dipole:  $G_D = 1.64, f = 300 \times 10^6 \Rightarrow \lambda = 1m$

$$P_t = 100W, P_L = P_t \cdot \frac{1.64^2 \cdot 1^2}{16\pi^2 \cdot (1500)^2} = 7.6 \times 10^{-7} W = 0.76 \mu W$$

(b)  $G_D = 1.5 \Rightarrow P_L = 6.33 \times 10^{-7} W = 0.633 \mu W$

**Radar equation:** Radar is a transmit–receive system.

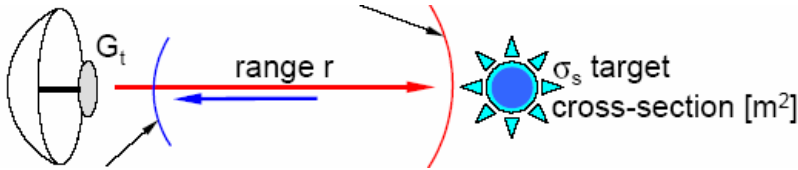

$\therefore$  Usually, a radar has an antenna to transmit or receive waves,  $\therefore G_{D1} = G_{D2} = G_D$ .

Define  $P_T = \frac{P_t G_D}{4\pi r^2}$  as power density at a distance  $r$ ,  $\frac{\sigma_{bs} P_T}{4\pi r^2}$  as power density

reflected by the target  $\Rightarrow P_L = A_e \cdot \frac{P_T \sigma_{bs}}{4\pi r^2} = A_e \sigma_{bs} \left(\frac{P_t}{(4\pi r^2)^2}\right) G_D(\theta, \phi)$

$$\therefore A_e = \frac{\lambda^2}{4\pi} G_D(\theta, \phi), \therefore \frac{P_L}{P_t} = \frac{\sigma_{bs} \lambda^2}{(4\pi)^3 r^4} G_D^2(\theta, \phi) = \frac{\sigma_{bs}}{4\pi} \left(\frac{A_e}{\lambda r^2}\right)^2$$

**Eg. Assuming that 50kW is fed into the antenna of a radar system operating at 3GHz. The antenna has an effective area of 4m<sup>2</sup> and a radiation efficiency of 90%. The minimum detectable signal power (over noise inherent in the receiving system and from the environment) is 1.5pW, and the power reflection coefficient for the antenna on receiving is 0.05. Determine the maximum usable range of the radar for detecting a target with a backscatter cross section of 1m<sup>2</sup>.**

(Sol.)  $f = 3 \times 10^9 \text{ Hz}, \sigma_{bs} = 1m^2, \lambda = 0.1m, A_e = 4m^2, P_t = 0.9 \times 5 \times 10^4 = 4.5 \times 10^4 W,$

$$P_L = 1.5 \times 10^{-12} \left(\frac{1}{1 - 0.05}\right) = 1.58 \times 10^{-12} W, \therefore r^4 = \frac{\sigma_{bs} A_e^2}{4\pi \lambda^2} \left(\frac{P_t}{P_L}\right), \therefore r = 4.2 \times 10^4 m$$

**Eg. The antenna at the earth station of a satellite communication link having a gain of 55dB at 14GHz is aimed at a geostationary satellite 36500km away. Assume that the antenna on the satellite has a gain of 35dB in transmitting the signal back toward the earth station at 12GHz. The minimum usable signal is 8pW. (a) Neglecting antenna ohmic and mismatch losses, find the minimum satellite transmitting power required. (b) Find the peak transmitting pulse power needed at the earth station in order to detect the satellite as a passive object, assuming the backscatter cross section of the satellite including its solar panels as 25m<sup>2</sup> and the minimum detectable return pulse power to be 0.5pW.**

$$\text{(Sol.) (a) } P_t = \frac{(4\pi r)^2}{G_e G_s \lambda_s^2} P_L, \lambda_e = 2.14 \times 10^{-2}, \lambda_s = 2.5 \times 10^{-2}, r = 3.65 \times 10^7 m, P_L = 8 \times 10^{-12} W,$$

$$G_e = 10^{55/10} = 3.16 \times 10^5, G_s = 10^{35/10} = 3.16 \times 10^3 \Rightarrow P_t = 2.7 W$$

$$\text{(b) } P_t = \frac{4\pi}{\sigma_{bs}} \left( \frac{\lambda_e r^2}{A_e} \right)^2 P_L, A_e = \frac{\lambda_e^2}{4\pi} G_e = 15.7 m^2 \Rightarrow P_t = 1.13 \times 10^9 W$$

### Radar Cross Section (RCS):

Define  $P_i$  as the time-average incident power density at the object,  $P_s$ : time-average scattered power density at the receiver site,  $\sigma_{bs}$ : backscatter cross section, and  $r$ : distance between scatter and receiver.  $\sigma_{bs} = 4\pi r^2 \frac{P_s}{P_i}$  or  $P_s = \frac{\sigma_{bs} P_i}{4\pi r^2}$ . **Note:**  $P_s$  is inversely proportional to  $r^2$  for large  $r$ , so that  $\sigma_{bs}$  does not change with  $r$ .

**Different** airplanes have **distinct** radar cross sections. A radar system can utilize this characteristic to identify the target.

## 中華民國空軍軍歌

凌雲御風去，報國把志伸，遨遊崑崙上空，俯瞰太平洋濱，看五嶽三江雄關要塞，  
美麗的錦繡河山，輝映著無敵機群，  
緬懷先烈莫辜負創業艱辛，發揚光大尤賴我空軍人，同志們努力，努力矢勇矢勤，  
國祚皇皇萬世榮。

盡瘁為空軍，報國把志伸，哪怕風霜雪露，只信雙手萬能，看鐵翼蔽空馬達齊鳴，  
美麗的錦繡河山，輝映著無敵機群，  
我們要使技術發明日日新，我們要用血汗永固中華魂，同志們努力，努力同德  
同心，國祚皇皇萬世榮。

Eg. A comparison among Mig-19, Mig-21, Mig-23, Mig-25, Su-27, 中共殲十戰鬥機 (above in PRC), IDF, F-16, Mirage-2000, and new IDF (above in ROC).

**Mig-19**



**Mig-21**



**Mig-23**



**Mig-25**



**Su-27**



**中共殲十(J-10)戰鬥機**



**IDF**



**F-16**



**Mirage-2000**



**new IDF**



**Stealth airplanes/vessels:** (1) Specific shape to reduce RCS. (2) Coating can be utilized to absorb EM waves radiated by enemy's radar systems.

**Eg. USA F-117 stealth bomber (airborne) and a comparison between F16, F22, and F35 fighters.**

**F-117**



**F22**



**F-16**



**F-35 CTOL**



**F-22**



**Eg. 中共可匿蹤之殲二十(J-20)戰鬥機與傳統式殲十戰鬥機。**

**J-20**



**J-10**



**Eg. A comparison between Lafeya vessel and a common vessel.**





Eg. 雷達未發明之前的空戰情況：我國 814 空戰英雄/空軍第 4 航空大隊大隊長高志航的電影「笕橋英烈傳」與美國支援對日抗戰飛虎隊陳納德將軍的紀錄片。



### 8-9 Wave Propagation near Earth's Surface

$$\vec{E} = \vec{E}_{\theta 1} + \vec{E}_{\theta 2}, \quad \text{where} \quad |\vec{E}_{\theta 1}| = k \left( \frac{e^{-j\beta R}}{R} \right) \sin \theta, \quad |\vec{E}_{\theta 2}| = \Gamma_{11}(\theta) k \left( \frac{e^{-j\beta R'}}{R'} \right) \sin \theta', \quad \text{and}$$

$$k = \frac{j I d \ell \eta_0 \beta}{4\pi}$$

$$\text{and } R' = \overline{AC} + \overline{BC} = \overline{A'B} = [d^2 + (h_2^2 + h_1^2)^2]^{1/2} \approx d + \frac{(h_2 + h_1)^2}{2d},$$

$$R = [d^2 + (h_2 - h_1)^2]^{1/2} \approx d + \frac{(h_2 - h_1)^2}{2d}, \quad \therefore R' - R = \frac{2h_1 h_2}{d}$$

$$\Rightarrow \vec{E}_{\theta} \approx \hat{a}_{\theta} k \left( \frac{e^{-j\beta R}}{R} \right) (\sin \theta) [1 + \Gamma_{11}(\theta) e^{-j\beta(R'-R)}]$$

$$= \hat{a}_{\theta} k \left( \frac{e^{-j\beta R}}{R} \right) (\sin \theta) [1 + \Gamma_{11}(\theta) e^{-j\beta(h_1 h_2 / d)}] = \hat{a}_{\theta} k \left( \frac{e^{-j\beta R}}{R} \right) (\sin \theta) \cdot F$$

$$\text{If the earth is perfect conducting, } \Gamma_{11}(\theta) = 1 \Rightarrow |F| = |1 - e^{-j2\beta(h_1 h_2 / d)}| = 2 \left| \sin \left( \frac{2\pi h_1 h_2}{\lambda d} \right) \right|.$$

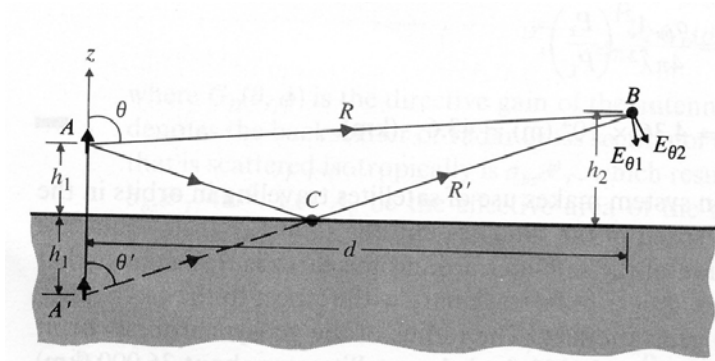

**Ex. A transmitting vertical half-wave dipole 60m above the ground radiated 400W at 100MHz. Assume the ground to be perfectly conducting. (a) Calculate the power available at a vertical half-wave receiving antenna 50km away at height 30m above the ground. (b) At a distance 50km from the transmitting antenna, where (at what altitudes) would there be a null field?**

$$\text{(Sol.) (a) } P_L = G^2 \left( \frac{\lambda}{4\pi r} \right)^2 P_t', \quad P_t' = |F|^2 P_t = \left\{ 2 \left| \sin \left( \frac{2\pi h_1 h_2}{\lambda d} \right) \right| \right\}^2 P_t$$

$$P_t = 400W, \quad h_1 = 60m, \quad h_2 = 30m, \quad \lambda = 3m, \quad d = 50000m \Rightarrow P_t' = 0.0225 P_t \approx 9W,$$

$$G=1.64 \Rightarrow P_L = 5.5 \times 10^{-10} W$$

$$\text{(b) Nulls: } \frac{2\pi h_1 h_2}{\lambda d} = n\pi, \quad h_1 = 60(m), \quad h_2 = 1.25n(m), \quad n=1, 2, 3, \dots$$

## 8-10 Broadband Antennas

**Frequency-independent Antenna:** The pattern and impedance characteristics are independent of frequency, because it is described entirely by angles, not dimension.

$$r = r_0 e^{a(\phi - \delta)}, \quad \phi - \delta = \frac{1}{a} \ln\left(\frac{r}{r_0}\right)$$

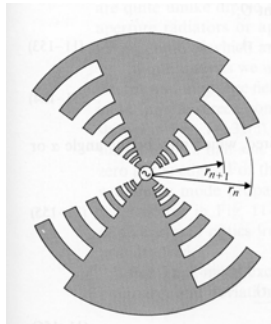
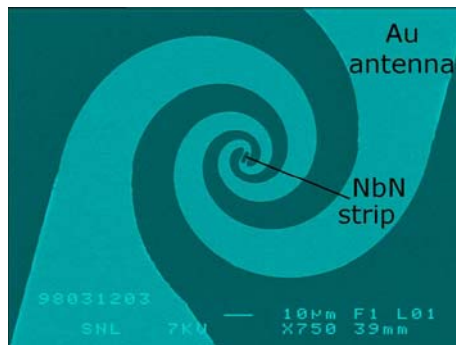
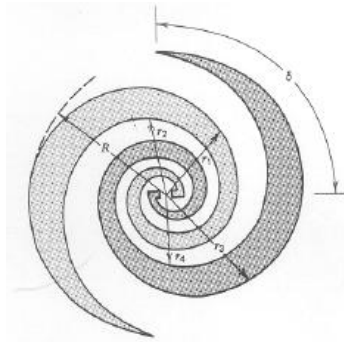

**Log-Periodic Antenna:** The antenna is operated in the discrete frequency.  $\frac{r_{n+1}}{r_n} = \frac{r_0 e^{a(\phi - \theta)}}{r_0 e^{a(\phi + 2\pi - \theta)}} = e^{-2\pi a} = \tau$ , where  $f_n = f_{n+1}$  or  $\ln(f_{n+1}) = \ln(f_n) + \ln\left(\frac{1}{\tau}\right)$

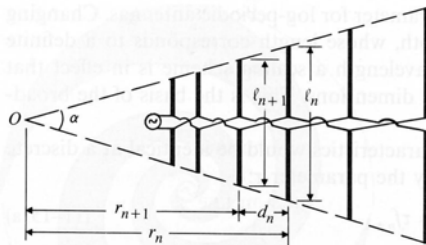

**Log-periodic Dipole Antenna:**  $\frac{\ell_{n+1}}{\ell_n} = \frac{r_{n+1}}{r_n} = \tau$ ,

$$d_n = r_n - r_{n-1} = r_n(1 - \tau) \quad (\text{or } \frac{d_{n+1}}{d_n} = \tau)$$

$$\tan \frac{\alpha}{2} = \frac{\ell_n}{2r_n} = \frac{\ell_n(1 - \tau)}{2d_n} = \frac{1 - \tau}{4\pi}$$

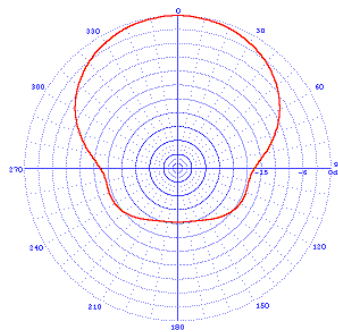

Azimuth pattern

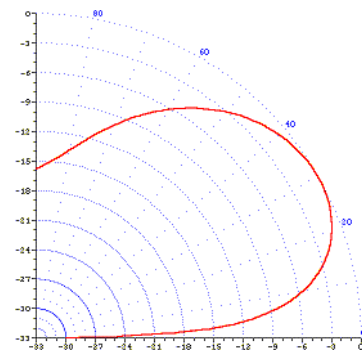

Elevation pattern



## 8-11 Waveguide Antennas

# WAVEGUIDE ANTENNAS

### Horn Antenna:

$TE_{10}$  expands to fill aperture

Diffraction in x-plane is Fourier transform of box,  
 $= (\sin \theta \pi d / \lambda) / (\theta \pi d / \lambda)$

Diffraction in y plane is Fourier transform of a half sine wave  
 (broader, but lower sidelobes)

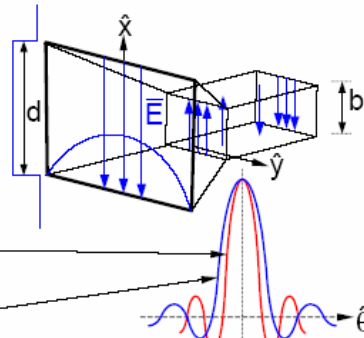

### Waveguide Slot Antennas:

Tilted slots radiate in proportion to tilt and current interrupted

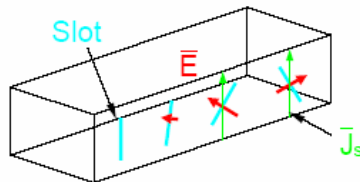

For uniform phased array, alternate tilts of alternate slots. Since  $\lambda_{\text{guide}} > \lambda_0$ , fill guide with  $\epsilon$  to shorten  $\lambda_{\text{guide}}$ .

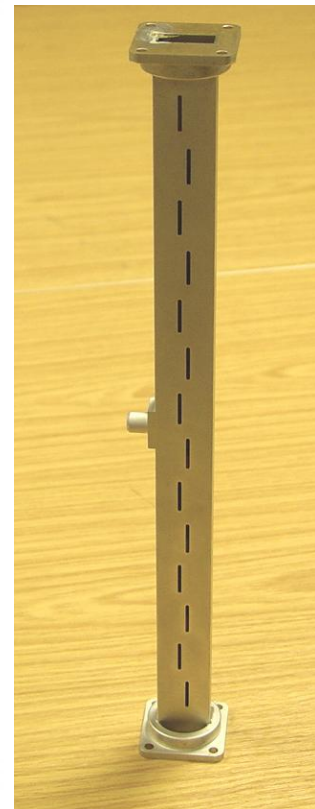
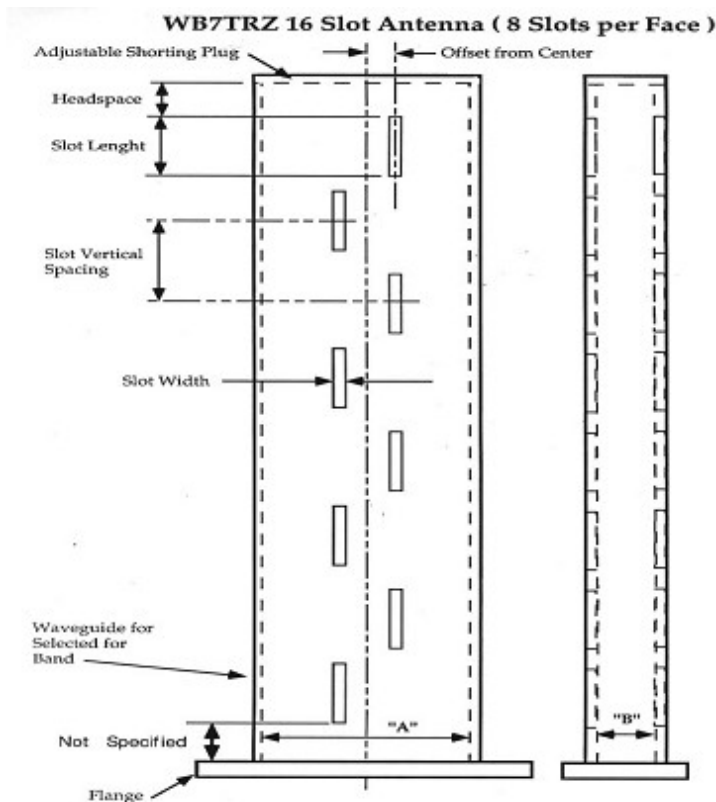

## 8-12 Reflector Antennas

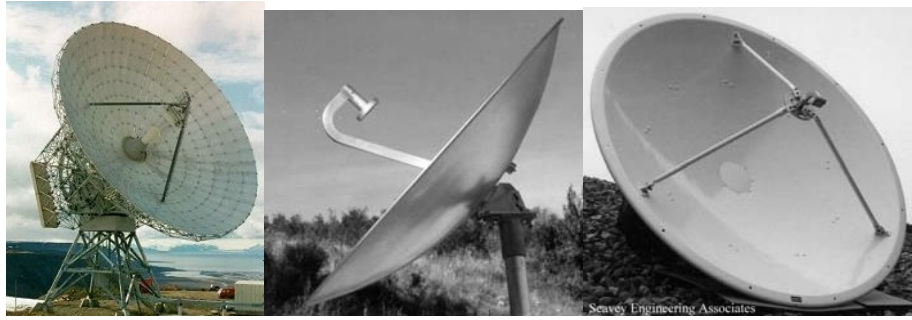

**Far-field formula:** 
$$\vec{E}(R, \theta, \phi) = \frac{-j\omega\mu_0 e^{-jkR}}{4\pi R} \iint_{\text{surface}} (\vec{J} - (\vec{J} \cdot \hat{a}_R) \hat{a}_R) e^{jk\rho' \cdot \hat{a}_R} dS(\theta', \phi'),$$

where  $\vec{J} = 2(\hat{a}_n \times \vec{H}_{inc})$ ,  $\vec{H}_{inc}$  is the incident magnetic field which is radiated by the feed,  $\hat{a}_n$  is the unit normal vector on the point of the reflector's surface,  $\rho'$  is the distance between the origin and the point of the reflector's surface.

In case of a circular parabolic reflector, of which focal length is  $f$ , the diameter of the aperture is  $D$ , focus is located at the origin, and the tip is at  $(x,y,z)=(0,0,-f)$ , then we

have 
$$\rho'(\theta', \phi') = \frac{2f}{1 - \cos \theta'} \quad , \quad \hat{a}_n = -\hat{x} \cos \frac{\theta'}{2} \cos \phi' - \hat{y} \cos \frac{\theta'}{2} \sin \phi' + \hat{z} \sin \frac{\theta'}{2} \quad ,$$

$$dS(\theta', \phi') = \rho'^2 \sin \theta' \csc \frac{\theta'}{2} d\theta' d\phi' \quad , \quad 2 \tan^{-1}(4f/D) \leq \theta' \leq \pi \quad , \quad \text{and } 0 \leq \phi' \leq 2\pi.$$

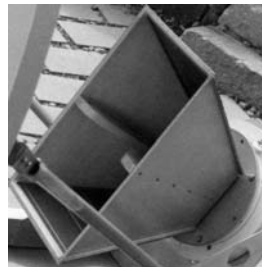

Feed of reflector antenna

### Classification of dual reflector antennas:

1. **Cassegrain Reflector:** It is a combination of a primary concave mirror and a secondary convex mirror, both aligned symmetrically about the optical axis. The primary mirror is of paraboloid type, while the secondary mirror is of hyperboloid type.
2. **Gregorian Reflector:** It consists of two mirrors; the primary mirror is a concave paraboloid which collects the light and brings it to a focus before the secondary mirror. The secondary mirror is an ellipsoid.

	Cassegrain Reflector		Gregorian Reflector	
Symmetrical Type				
Non-symmetrical Type				

### 8-13 Aperture Antennas

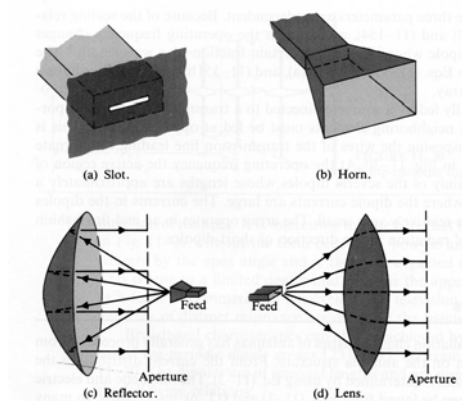

$$\vec{E}_a = \hat{x}E_a, P(R_0, \theta, \phi) \text{ at the far zone } (\beta R \gg 1)$$

$$\vec{E}_p = \hat{x}E_p, \text{ where } \vec{E}_p = \frac{j}{\lambda R_0} \iint_{\text{aperture}} \vec{E}_a(x', y') e^{-j\beta R} dx' dy'$$

$$\because \beta R \gg 1,$$

$$\therefore R \approx R_0 - (\hat{x}' + \hat{y}') \cdot (\hat{x} \sin \theta \cos \phi + \hat{y} \sin \theta \sin \phi)$$

$$= R_0 - (x' \sin \theta \cos \phi + y' \sin \theta \sin \phi)$$

$$\Rightarrow \vec{E}_p = \frac{j}{\lambda R_0} e^{-j\beta R_0} \cdot F(\theta, \phi), \text{ where}$$

$$F(\theta, \phi) = \iint_{\text{aperture}} \vec{E}_a(x', y') e^{j\beta \sin \theta (x' \cos \phi + y' \sin \phi)} dx' dy'$$

$$\text{Directivity: } D = \frac{4\pi U_{\max}}{P_r}, U_{\max} = \frac{1}{2\eta_0} R_0^2 |\vec{E}_p|_{\max}^2 = \frac{1}{2\eta_0 \lambda^2} \left| \iint \vec{E}_a(x', y') dx' dy' \right|^2$$

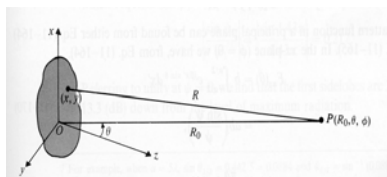

$$P_r = \frac{1}{2\eta_0} \iint |\vec{E}_a(x', y')|^2 dx' dy' \Rightarrow D = \frac{4\pi}{\lambda^2} \frac{\left| \iint_{\text{aperture}} \vec{E}_a(x', y') dx' dy' \right|^2}{\iint_{\text{aperture}} |\vec{E}_a(x', y')|^2 dx' dy'}$$

If  $E_a(x', y')$  is constant  $\Rightarrow D = 4\pi/\lambda^2$

Case 1  $\phi = 0$  (in the  $xz$ -plane)

Case 2  $\phi = \pi/2$  (in the  $yz$ -plane)

**Eg. Assume that the field in an  $a \times b$  rectangular aperture in an  $xy$ -plane is linearly polarized in the  $y$ -direction and that the aperture excitation has a uniform phase and a triangular amplitude distribution  $f(x) = 1 - \left| \frac{2}{a} x \right|$ ,  $|x| \leq \frac{a}{2}$ . Find (a) the pattern function in the  $xz$ -plane, (b) the half-power beamwidth, (c) the location of the first nulls, and (d) the level of the first sidelobes.**

(Sol.) (a) The  $xz$ -plane  $\Rightarrow \phi = 0$ ,  $\cos \phi = 1$ ,  $\sin \phi = 0$ ,  $E_a(x', y') = f(x) \cdot 1$

$$F(\theta, \phi) = \iint_{\text{aperture}} E(x', y') \cdot e^{j\beta \sin \theta (x' \cos \phi + y' \sin \phi)} dx' dy'$$

$$F(\theta, \phi = 0) = \int_{-a/2}^{a/2} \left[ 1 - \left| \frac{2}{a} x \right| \right] e^{j\beta x' \sin \theta} dx' \cdot \int_{-b/2}^{b/2} 1 \cdot dy' = \frac{ab}{2} \cdot \frac{\sin^2 \left( \frac{\beta a}{\psi} \sin \theta \right)}{\left( \frac{\beta a}{\psi} \sin \theta \right)^2} = F_{xz}(\theta)$$

$$(b) \frac{\sin^2 \left( \frac{\beta a}{\psi} \sin \theta \right)}{\left( \frac{\beta a}{\psi} \sin \theta \right)^2} = \frac{1}{\sqrt{2}} \Rightarrow 2\Delta\theta \approx 2 \times 0.326 \frac{\pi\lambda}{a} = 0.652 \times \frac{\lambda}{a}$$

$$(c) \sin \left( \frac{\beta a \sin \theta}{\psi} \right) = 0 \Rightarrow \theta_{null} = \sin^{-1} \left( \frac{2\lambda}{a} \right)$$

$$(d) \frac{d}{d\psi} \left( \frac{\sin^2 \psi}{\psi^2} \right) = 0 \Rightarrow \psi = \frac{3\pi}{2} \Rightarrow \frac{\sin^2 \psi}{\psi^2} = 0.045$$

$$\therefore \text{The first sidelobe level} = 20 \log_{10} \left( \frac{1}{0.045} \right) = 26.9 \text{ dB}$$

**Eg. A linearly polarized uniform electric field  $\vec{E}_a = \hat{x}E_0$  exists in a circular aperture of radius  $b$  in a conducting plane at  $z=0$ . Assuming  $b$  to be large in comparison to wavelength, (a) find an expression for the far-zone electric field, and (b) determine the width of the main beam between first nulls.**

(Sol.) (a)  $x' = \rho' \cos \phi'$ ,  $y' = \rho' \sin \phi'$ , and

$$x' \cos \phi + y' \sin \phi = \rho' (\cos \phi \cos \phi' + \sin \phi \sin \phi') = \rho' \cos(\phi - \phi')$$

$$F(\theta, \phi) = E_0 \int_0^b \int_0^{2\pi} e^{j\beta \rho' \sin \theta \cos(\phi - \phi')} \rho' d\phi' d\rho' = E_0 \int_0^b 2\pi J_0(\beta \rho' \sin \theta) \rho' d\rho' = E_0 2\pi b^2 \left[ \frac{J_1(\beta b \sin \theta)}{\beta b \sin \theta} \right]$$

$$\vec{E}_p = \hat{a}_x jE_0 \frac{2\pi b^2}{\lambda R_0} e^{-j\beta R_0} \left[ \frac{J_1(u)}{u} \right], \text{ where } u = \beta b \sin \theta = \frac{2\pi b}{\lambda} \sin \theta.$$

(b) The first null of the radiation pattern occurs at the first zero of  $J_1(u)$ :  $u_{11} = 3.832$

$$\theta_1 = \sin^{-1} \left( \frac{3.832\lambda}{2\pi b} \right) \cong \frac{3.832\lambda}{2\pi b} = 1.22 \frac{\lambda}{D} \text{ (rad)}, \text{ where } D=2b. \text{ The width of the main beam}$$

$$\text{between the first nulls is } 2\theta_1 = 2.44\lambda / D \text{ (rad)}.$$

**Formulae:**  $\int_0^{2\pi} e^{j\omega \cos \phi'} d\phi' = 2\pi J_0(\omega)$  and  $\int w J_0(w) dw = w J_1(w)$